

The City of Edgewater

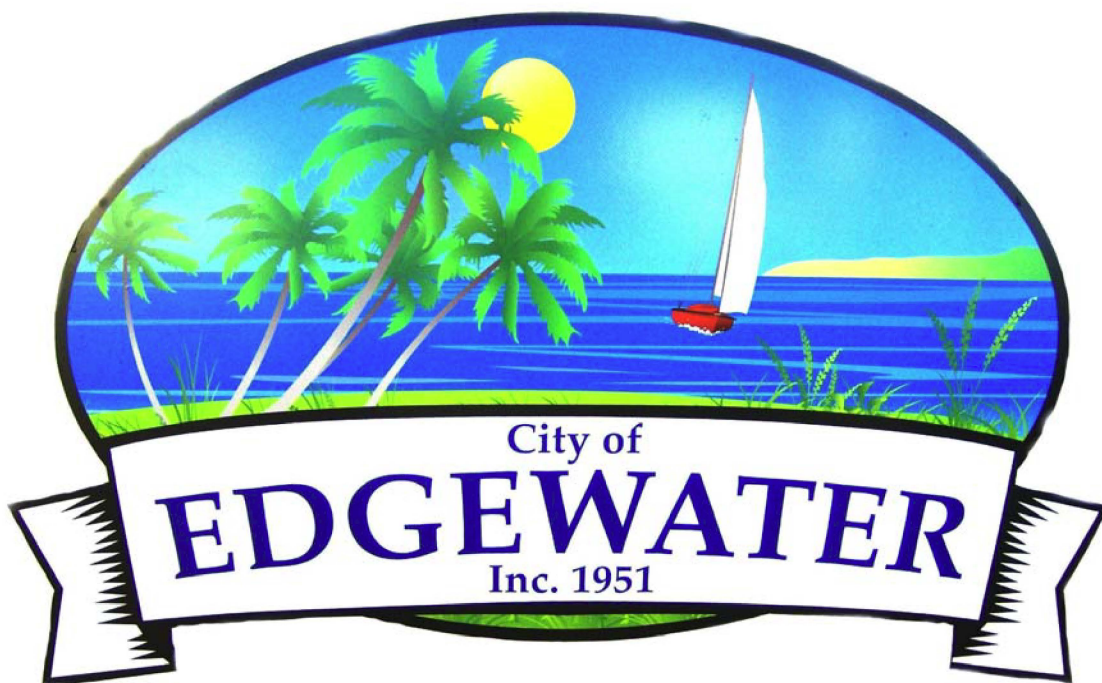

STANDARD CONSTRUCTION DETAILS

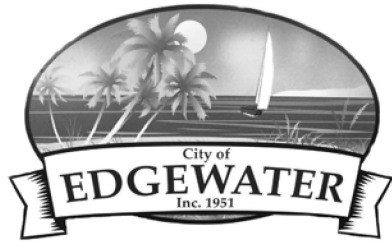

CITY OF EDGEWATER

STANDARD CONSTRUCTION DETAILS

CITY OF EDGEWATER
DEPARTMENT OF ENVIRONMENTAL SERVICES
409 MANGO TREE DRIVE
EDGEWATER, FLORIDA 32132
TELEPHONE (386) 424-2476
FAX (386) 424-2480

INDEX

RECLAIMED WATER DETAILS

RW-1	RECLAIMED WATER SERVICE: IRRIGATION (SPRINKLER) CONNECTION
RW-2	RECLAIMED WATER SERVICE: SINGLE SERVICE METER BOX
RW-3	RECLAIMED WATER SERVICE: SPRINKLER/"HOSE BIBB" ASSEMBLY
RW-4	RECLAIMED WATER MAIN VALVE BOX
RW-5	RECLAIMED WATER DESIGN AND CONSTRUCTION NOTES
RW-6	RECLAIMED WATER DESIGN AND CONSTRUCTION NOTES
RW-7	RECLAIMED WATER DESIGN AND CONSTRUCTION NOTES

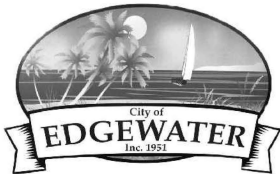

STANDARD CONSTRUCTION DETAIL
INDEX
RECLAIMED WATER DETAILS

FILE NAME:
RWINDEX.DWG

DETAIL REF:
INDEX



STANDARD CONSTRUCTION DETAIL
 RECLAIMED WATER SERVICE:
 IRRIGATION (SPRINKLER) CONNECTION

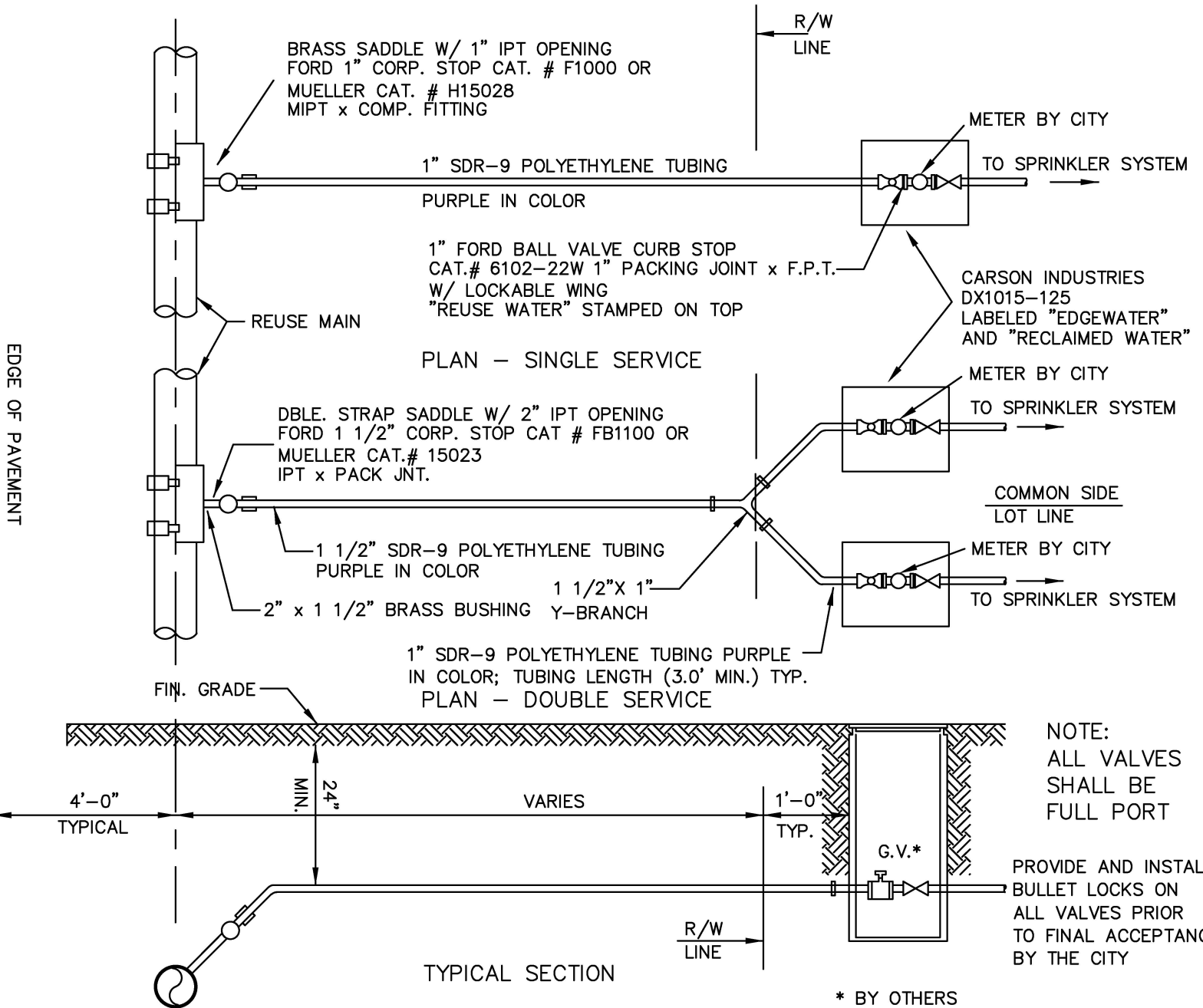

NOTE:
 ALL VALVES
 SHALL BE
 FULL PORT

PROVIDE AND INSTALL
 BULLET LOCKS ON
 ALL VALVES PRIOR
 TO FINAL ACCEPTANCE
 BY THE CITY

FILE NAME:

EW_RW1.DWG

DETAIL REF:

RW-1

CAST IRON FLIP LID
 COVER BOLTDOWN OPTION
 SKID RESISTANT SURFACE
 5/8" X 4" LIFTING SLOT

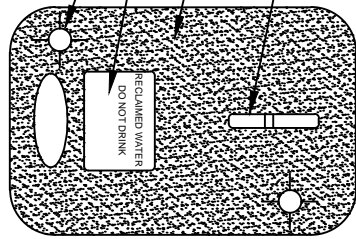

COVER

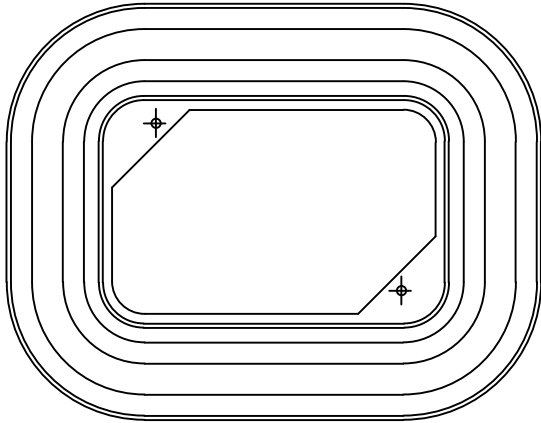

BOX PLAN VIEW

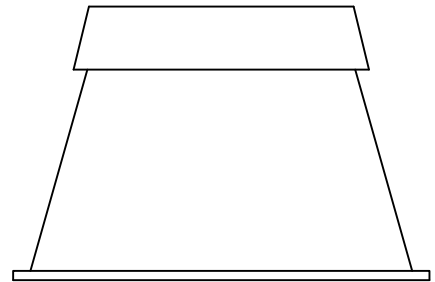

END VIEW

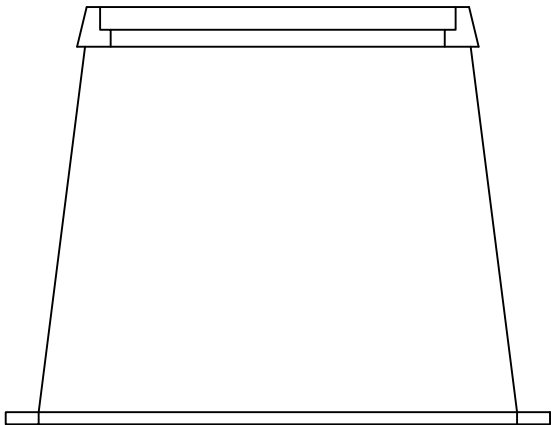

BOX AND COVER SECTION

NOTES:

1. ALL BOXES AND COVERS TO BE PURPLE.

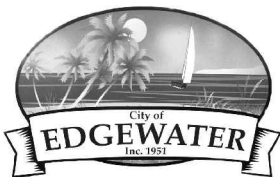

STANDARD CONSTRUCTION DETAIL
 RECLAIMED WATER SERVICE:
 SINGLE SERVICE
 METER BOX

FILE NAME:

EW_RW2.DWG

DETAIL REF:

RW-2

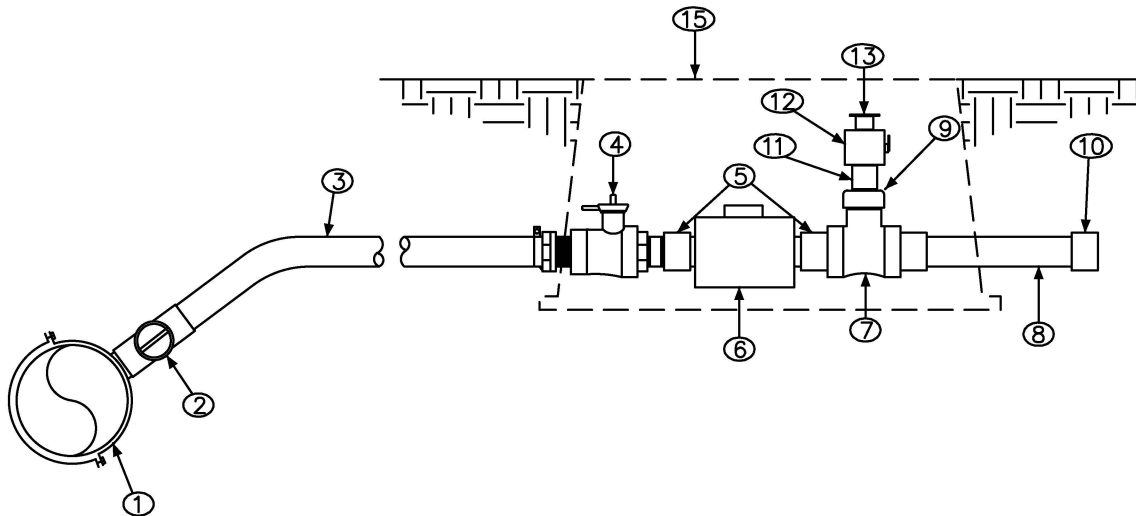

- | | |
|---|--|
| <ul style="list-style-type: none"> (1) BRASS SADDLES 1" CC (2) 1" CORP STOP CC FORD (3) 1" PURPLE H.D.P.E. PIPE (4) 1" P.J. x 3/4" BALL VALVE x 3/4" METER COUPLING. FORD #B43-342W. (5) 3/4" METER COUPLING x 3/4" M.I.P. 1 7/16" LAY LENGTH. FORD #C38-23-1.437 (6) METER (BY CITY) (7) 1 - 1" PVC THREADED TEE SCH. 80 (8) 1- 1" X 8' PVC SCH. 80 THREADED BOTH ENDS | <ul style="list-style-type: none"> (9) 1 - 1" X 3/4" PVC SCH. 40 BUSHING (10) 1 - 1" PVC SCH. 40 THREADED CAP (11) 1 - 3/4" CLOSE NIPPLE (12) 1 - 3/4" BRASS BALL VALVE WITH BRASS HANDLE (13) 1 - 3/4" QUICK DISCONNECT HOSE FITTING (14) 1 - WILKINS D.C. #950 XLT (15) 1 - PURPLE POLY PLASTIC BOX |
|---|--|

NOTES:

1. ALL VALVES TO BE "FULL PORT". THIS UNIT IS TO BE PREASSEMBLED AND HYDROSTATICALLY TESTED TO 100 PSI. ALL MALE THREADS ARE TO BE COVERED AS REQUIRED WITH 3/4" DOMESTIC TEFLON TAPE AND A THREAD SEALING COMPOUND TO BE REMOVED PRIOR TO SHIPMENT.
2. ALL EXPOSED MALE THREADS TO BE PROTECTED BY PLASTIC CAPS PRIOR TO SHIPMENT.
3. ALL POLYETHYLENE TUBING SHALL BE PURPLE.
4. TYPICALLY THIS DEVICE TO BE INSTALLED BY CITY FORCES.

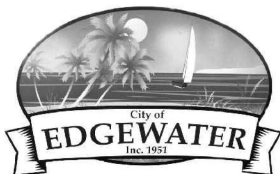

STANDARD CONSTRUCTION DETAIL
RECLAIMED WATER SERVICE:
SPRINKLER/ " HOSE BIBB " ASSEMBLY

FILE NAME:

EW_RW3.DWG

DETAIL REF:

RW-3

COVER MARKED
"RECLAIMED WATER"
AND PAINTED PURPLE

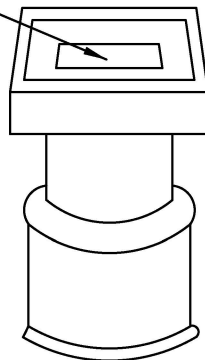

20" x 20" x 4"
CONC. COLLAR
W/ 1 x 4 CONT.
(REQ'D IN UNPAVED
AREAS ONLY)

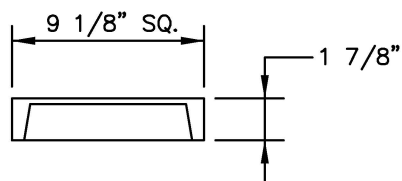

COVER

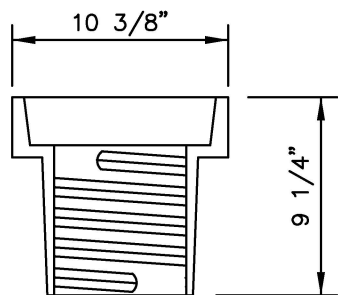

TOP
SECTION

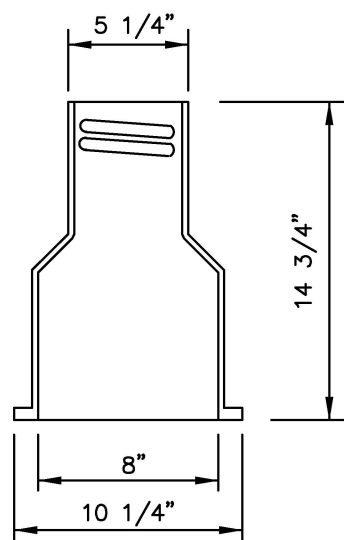

BOTTOM
SECTION

NOTE:

1. RECLAIMED MAIN VALVE BOX AND COVER SHALL BE ADJUSTABLE SCREW TYPE.

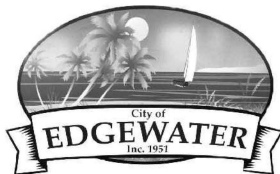

STANDARD CONSTRUCTION DETAIL
RECLAIMED WATER MAIN
VALVE BOX

FILE NAME:

EW_RW4.DWG

DETAIL REF:

RW-4

RECLAIMED WATER DESIGN AND CONSTRUCTION NOTES

1. THE CITY'S PUBLIC UTILITIES DEPARTMENT (424-2460) SHALL BE GIVEN A MINIMUM OF 48 HOURS ADVANCE NOTICE (NOT INCLUDING HOLIDAYS OR WEEKENDS) PRIOR TO BEGINNING ANY RECLAIMED WATER SYSTEM CONSTRUCTION.
2. DEWATERING SHALL BE PROVIDED TO KEEP GROUNDWATER ELEVATION A MINIMUM OF 6 INCHES BELOW RECLAIMED WATER MAIN BEING LAID.
3. ALL RECLAIMED WATER MAINS SHALL BE LAID ON A FIRM FOUNDATION WITH ALL UNSUITABLE MATERIAL (MUCK, ROCK, COQUINA, ETC.) REMOVED AND REPLACED WITH CLEAN GRANULAR MATERIAL.
4. TRENCHES SHALL BE BACKFILLED WITH MATERIAL ACCEPTABLE TO THE CITY WITH A MINIMUM COMPACTION OF 95% IN UNPAVED AREAS AND 98% IN PAVED AREAS IN ACCORDANCE WITH AASHTO T-180.
5. IT SHALL BE THE CONTRACTORS RESPONSIBILITY TO ENSURE THAT TRENCH COMPACTION TESTS BE PROVIDED AT POINTS 1 FOOT ABOVE THE PIPE AND AT 1 FOOT VERTICAL INTERVALS TO FINISH GRADE, AT A MINIMUM SPACING OF EVERY 300 FEET
6. 3" METALLIZED PIPE LOCATION TAPE SHALL BE LOCATED BETWEEN 15" AND 24" BELOW FINISHED GRADE OR AS SPECIFIED BY MANUFACTURER FOR ALL PVC LINES. IN ADDITION TO 12 GAUGE TRACING WIRE MARKER TAPE SHALL BE PROVIDED ON ALL DIP PIPE ALSO.
7. ALL SINGLE RESIDENTIAL WATER SERVICES SHALL BE 1" AND DOUBLE RESIDENTIAL SERVICES SHALL BE 1 1/2". SERVICES SHALL BE CTS 3408 HIGH DENSITY POLYETHYLENE TUBING RATED FOR A MINIMUM OF 200 PSI WITH SDR 9 (CTS). THE TUBING SHALL HAVE A VIRGIN HIGH DENSITY POLYETHYLENE CENTER FOR WHICH THE MANUFACTURER SHALL FURNISH A CERTIFICATE OF PURITY. THE TUBING SHALL BE LAVENDER IN COLOR AND SHALL HAVE THE WORDS "RECLAIMED WATER" PERMANENTLY PRINTED ON THE OUTSIDE. THE TUBING SHALL HAVE U.V. PROTECTION AND SHALL NOT BE AFFECTED BY DIRECT SUNLIGHT. THE TUBING SHALL COMPLY WITH OR EXCEED THE APPLICABLE STANDARDS OF A.S.D.M. D1248, D3350, D2239, D2737, N.S.F.-14 AND A.W.W.A. C901 AND SHALL COME WITH A LIFETIME WARRANTY. APPROVED SIZES: 3/4", 1", 1-1/2" AND 2" DIAMETERS. ACCEPTABLE MANUFACTURERS: ENDOT ENDOCORE RWT OR APPROVED EQUAL
8. ALL WATER SERVICE ENDINGS SHALL BE SECURED BY WIRE TO 2"X 4" PRESSURE TREATED STAKES, APPROXIMATELY 2' ABOVE GRADE, WITH "U" BRANCHES AT THE GROUND LEVEL, OR MAY BE PLACED IN RECLAIMED WATER METER BOXES AS SUPPLIED BY THE CITY AT THE TIME OF FINAL SUBDIVISION INSPECTION.
9. RECLAIMED WATER VALVES SHALL BE PLACED AT ALL STREET INTERSECTIONS AND AT MAXIMUM SPACINGS OF 1000 FEET.
10. AT ALL RECLAIMED WATER MAIN TEES AND CROSSES, VALVES SHALL BE INSTALLED ON ALL LEGS EXCEPT ONE.
11. APPROVED WATER VALVE TYPES ARE THE FOLLOWING:
 - A. STANDARD GATE VALVES LESS THAN 24" DIAMETER (AWWA C-500) OR RESILIENT SEAT GATE VALVES (AWWA C-509)
 - B. BUTTERFLY VALVES GREATER THAN 24" (AWWA C 504)
 - C. TAPPING VALVES WITH MECHANICAL OR STAINLESS STEEL TAPPING SLEEVE.
12. ALL RECLAIMED WATER VALVES SHALL BE ADJUSTED TO FINISH GRADE AND THE CAPS SHALL BE PAINTED LAVENDER OR PURPLE TO MAKE THEM PLAINLY DISTINGUISHABLE.
13. AS STANDARD PRACTICE RECLAIMED WATER MAINS SHALL BE INSTALLED 4 FEET OFF THE BACK OF THE CURB ON THE OPPOSITE SIDE OF THE POTABLE WATER LINES OR AS APPROVED BY THE CITY.
14. ALL RECLAIMED WATER MAINS SHALL HAVE A MINIMUM COVER OF 36 INCHES. IN SPECIAL CASES WHERE IT IS IMPOSSIBLE OR INAPPROPRIATE TO PROVIDE ADEQUATE COVER, DUCTILE IRON PRESSURE CLASS 350 OR CONCRETE ENCASEMENT MAY BE USED AS APPROVED BY THE CITY.
15. ALL MAINS INSTALLED REQUIRE 12 GAUGE TRACING WIRE FOR LOCATING.

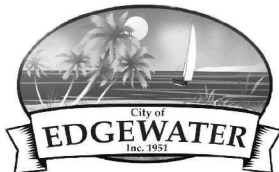

STANDARD CONSTRUCTION DETAIL RECLAIMED WATER DESIGN AND CONSTRUCTION NOTES

FILE NAME:

EW_RW5.DWG

DETAIL REF:

RW-5

RECLAIMED WATER DESIGN AND CONSTRUCTION NOTES (CONTD.)

15. ALL PROPOSED RECLAIMED WATER MAINS SHALL BE FLUSHED, DISINFECTED PRESSURE TESTED AND BACTERIOLOGICALLY CLEARED FOR SERVICE WHEN APPROPRIATE IN ACCORDANCE WITH LATEST AWWA STANDARDS AND THE FLORIDA DEPARTMENT OF ENVIRONMENTAL PROTECTION REQUIREMENTS. THE CONTRACTOR SHALL NOTIFY THE CITY'S DESIGNATED SITE INSPECTOR WHO SHALL COORDINATE WITH CITY PERSONNEL AT THE WASTEWATER PLANT 48 HOURS PRIOR TO BEGINNING A FULL-DIAMETER FLUSH OF THE MAINS PRIOR TO THE COMMENCEMENT OF PRESSURE TESTING.
16. THE CONTRACTOR SHALL BE REQUIRED TO PIG ALL RECLAIMED MAINS IN EXCESS OF 8" IN DIAMETER AND PRIMARY DISTRIBUTION MAINS LOCATED ON COLLECTOR AND ARTERIAL ROADWAYS. LAUNCHING AND EXTRACTION POINTS SHALL BE DETERMINED BY THE CONTRACTOR.
17. RECLAIMED WATER MAINS SHALL BE PVC AWWA CLASS C-900 OR C-905, CL 150 (COLOR PANTONE PURPLE) OR DIP PRESSURE CLASS 350, STANDARD CEMENT LINED UNLESS APPROVED OTHERWISE BY THE CITY.
18. ALL RECLAIMED WATER MAINS SHALL USE A THRUST RESTRAINED JOINT METHOD IN COMPLIANCE WITH THE DUCTILE IRON PIPE RESEARCH ASSOCIATION (DIPRA) GUIDELINES. IN THE EVENT THAT PVC FITTINGS ARE SPECIFIED, THE RESTRAINED JOINT SHALL BE MODIFIED IN ACCORDANCE WITH THE RECOMMENDED ADDITIONAL RESTRAINED LENGTH REQUIRED FOR PIPE WRAPPED WITH POLYETHYLENE. IN NO INSTANCE SHALL THRUST BLOCKS BE PERMITTED.
19. MEGALUGS, BOLTLESS RESTRAINED JOINTS, OR GRIPPER GASKETS SHALL BE USED ON ALL RESTRAINED JOINT INSTALLATIONS. MINIMUM DEPTH OF BURY ON PIPES NOT MEETING REQUIRED COVER REQUIREMENTS SHALL FOLLOW THE MOST RECENT DIPRA THRUST RESTRAINT DESIGN GUIDELINES.
20. GRIPPER RING GASKETS BY ROMAC MAY BE USED AS APPROPRIATE FOR RESTRAINING PRESSURE PIPE TO FITTINGS, VALVES, ETC.
21. UPON CONSTRUCTION COMPLETION AND ACCEPTANCE OF THE SYSTEM, IT SHALL BE THE DESIGN ENGINEER'S RESPONSIBILITY TO INSURE THAT THE SYSTEM IS PROPERLY CERTIFIED AND ACCEPTED BY THE DEPARTMENT OF ENVIRONMENTAL PROTECTION OR CITY OF EDGEWATER PUBLIC UTILITIES AND "AS-BUILTS" ARE PROVIDED TO THE CITY, PRIOR TO ANY USE OF THIS SYSTEM.
22. ALL RECLAIMED WATER MAINS AND SERVICE LINES SHALL BE READILY DISTINGUISHABLE BY THEIR PURPLE COLOR OR TAPE MARKINGS. DUCTILE IRON PIPE SHALL BE WRAPPED WITH PURPLE POLYETHYLENE.
23. ALL RECLAIMED WATER SERVICES SHALL BE MARKED ALONG THE OUTSIDE EDGE OF CURB WITH AN "⊥" OR BY METAL TABS SET INTO PAVEMENT. VALVES AND BLOW-OFFS FOR RECLAIM WATER MAINS SHALL BE MARKED BY AN "X" SET INTO THE PAVEMENT.
24. ALL DIP PIPE SHALL HAVE 2" YELLOW STRIPES PAINTED AT 2 O'CLOCK, 6 O'CLOCK, AND 10 O'CLOCK FOR THE FULL LENGTH OF PIPE. YELLOW TRAFFIC STRIPING PAINT SHALL BE USED WITH RECLAIMED WATER CLEARLY STENCILED WITH PAINT AT TWO LOCATIONS PER STRIPE OR SIX PER PIPE.
25. RECLAIM WATER SERVICES SHALL BE NORMALLY DOUBLE 1 1/2" SERVICES LOCATED AT SIDE LOT LINES ALTERNATING WITH POTABLE WATER SERVICE LOCATIONS. IN INSTANCES WHERE RECLAIM WATER SERVICES NEED TO BE OFFSET, 1" SINGLE SERVICES SHALL BE SPECIFIED THESE SERVICES MAY BE OFFSET FROM THE LOT LINE A MAXIMUM DISTANCE OF 2.0'.
26. MAXIMUM OBTAINABLE SEPARATION OF PUBLIC RECLAIMED WATER MAINS, STORMWATER MAINS, AND SANITARY SEWER MAINS SHALL BE MAINTAINED. A MINIMUM HORIZONTAL SEPARATION OF FIVE (5) FEET (CENTER TO CENTER) OR THREE (3) FEET (OUTSIDE TO OUTSIDE) SHALL BE MAINTAINED BETWEEN RECLAIMED WATER MAINS AND SEWAGE MAINS. WHERE RECLAIMED WATER AND SANITARY SEWAGE MAINS CROSS WITH LESS THAN EIGHTEEN (18) INCHES VERTICAL CLEARANCE, THE SANITARY SEWAGE MAIN SHALL BE TWENTY (20) FEET OF EITHER CONCRETE ENCASED PVC PIPE OR ENCASED IN A WATERTIGHT CARRIER PIPE, CENTERED ON THE POINT OF CROSSING

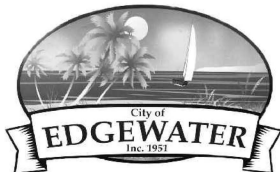

STANDARD CONSTRUCTION DETAIL
RECLAIMED WATER DESIGN AND CONSTRUCTION NOTES

FILE NAME:

EW_RW6.DWG

DETAIL REF:

RW-6

RECLAIMED WATER DESIGN AND CONSTRUCTION NOTES (CONTD.)

27. MAXIMUM OBTAINABLE SEPARATION OF PUBLIC ACCESS RECLAIMED WATER MAINS AND POTABLE WATER MAINS SHALL BE MAINTAINED. A MINIMUM HORIZONTAL SEPARATION OF FIVE (5) FEET (CENTER TO CENTER) OR THREE (3) FEET (OUTSIDE TO OUTSIDE) SHALL BE MAINTAINED BETWEEN RECLAIMED WATER MAINS AND POTABLE WATER MAINS. WHERE RECLAIMED WATER AND POTABLE WATER MAINS CROSS WITH LESS THAN EIGHTEEN (18) INCHES VERTICAL CLEARANCE, THE RECLAIMED WATER MAIN SHALL BE TWENTY (20) FEET OF EITHER DUCTILE IRON PIPE OR ENCASED IN A WATERTIGHT CARRIER PIPE, CENTER ON THE POINT OF CROSSING.
28. ALL RECLAIMED WATER HOSE BIBBS, HAND-OPERATED CONNECTIONS AND OUTLETS SHALL BE CONTAINED IN UNDERGROUND SERVICE VAULTS AND SHALL BE APPROPRIATELY TAGGED OR LABELED TO WARN THE PUBLIC AND EMPLOYEES THAT THE WATER IS NOT INTENDED FOR DRINKING. ALL PIPING, VALVES, AND OUTLETS SHALL BE COLOR-CODED, OR OTHERWISE MARKED, TO DIFFERENTIATE RECLAIMED WATER FROM POTABLE OR OTHER WATER.
29. VAULTS FOR HOSE BIBBS AND OUTLETS SHALL BE LOCKED OR REQUIRE A SPECIAL TOOL FOR OPERATION OF HOSE BIBBS AND OUTLETS.
30. THE REUSE MAIN SHALL NOT BE PLACED IN SERVICE UNTIL A SATISFACTORY 150 PSI PRESSURE TEST AND A PASSING BACTERIOLOGICAL TEST IS PERFORMED AND RESULTS ARE FORWARDED TO THE CITY.
31. A 75 FOOT SETBACK DISTANCE SHALL BE PROVIDED FROM PUBLIC ACCESS REUSE WETTED AREAS TO ANY PUBLIC AND ANY PRIVATE POTABLE WATER SUPPLY WELLS.
32. LOW TRAJECTORY NOZZLES ARE REQUIRED WITHIN 100 FEET OF PUBLIC EATING, DRINKING OR BATHING FACILITIES.
33. ALL TAPPING OF MAINS SHALL BE SUPERVISED BY THE CITY SCHEDULING OF THESE CONNECTIONS SHALL REQUIRE A MINIMUM 48 HOUR NOTIFICATION (MEASURED ON NORMAL WORK DAYS) DIRECTED TO THE CITY'S DESIGNATED SITE INSPECTOR. SUBSEQUENTLY, THE CONNECTION SHALL BE SCHEDULED TO COMMENCE BETWEEN 7:00 A.M. AND NOON ON THE APPROPRIATE DAY.
34. WITH RESPECT TO TIE-IN CONNECTIONS, THE CITY RESERVES THE RIGHT TO REQUIRE CONNECTIONS TO BE PERFORMED DURING PERIODS OF LOW FLOW IN ORDER TO MINIMIZE MINIMIZE SERVICE DISRUPTION TO EXISTING CUSTOMERS.
35. ALL WORK PERFORMED UPON RECLAIMED WATER FACILITIES OWNED OR PROPOSED TO BE OWNED BY THE CITY SHALL BE CONSTRUCTED BY AN UNDERGROUND UTILITY OR GENERAL CONTRACTOR LICENSED IN THE STATE OF FLORIDA AND REGISTERED WITH THE CITY.
36. FOR CONSTRUCTION PURPOSES, THE PLANS SHALL DIMENSION THE PROPOSED LOCATIONS OF ALL RECLAIMED WATER MAINS MEASURED FROM THE BACK OF CURB (OR EDGE OF PAVEMENT IF NO CURB EXISTS).
37. ALL H.D.P.E. PIPE RECLAIMED WATER MAINS SHALL BE S.D.R.11 UNLESS SPECIFICALLY NOTED OTHERWISE. THE HDPE PIPE SHALL BE SIZED TO MATCH THE EXTERNAL DIAMETER OF THE PVC OR DIP PIPE TO WHICH IT IS ATTACHED.
38. LANDSCAPE PLANS SHALL CLEARLY DEPICT THE DESIGN LOCATION OF PLANTINGS RELATIVE TO THE LOCATION OF PUBLIC UTILITIES AND STORMWATER INFRASTRUCTURE IN ORDER TO EVALUATE POTENTIAL CONFLICTS.



STANDARD CONSTRUCTION DETAIL
RECLAIMED WATER DESIGN AND CONSTRUCTION NOTES

FILE NAME:

EW_RW7.DWG

DETAIL REF:

RW-7