

INDEX

WATER DETAILS

- W-1 FIRE HYDRANT ASSEMBLY
- W-2 POTABLE AND/OR REC. WATER VALVE AND VALVE BOX (2"-16" VALVE SIZE)
- W-3 TAPPING VALVE AND SLEEVE
- W-4 AIR RELEASE VALVE PIT
- W-5 WATER LATERAL SERVICE (3/4" - 2" SIZES)
- W-6 POTABLE WATER BLOW OFF ASSEMBLY
- W-7 PVC TO HDPE RESTRAINED JOINT DETAIL
- W-8 WATER METER BOX (METER 3" AND LARGER SIZES)
- W-9 3" - 8" WATER METER BOX
- W-10 BACKFLOW PREVENTER (REDUCED PRESSURE) 3" - 8"
- W-11 2" BACKFLOW PREVENTER
- W-12 CONDUIT CROSSING R.R. OR ROADWAY
- W-13 CONDUIT CROSSING R.R. OR ROADWAY
- W-14 STORM DRAINAGE PIPE OR SANITARY SEWER MAIN CONFLICT
- W-15 STORM DRAINAGE PIPE OR SANITARY SEWER MAIN CONFLICT
- W-16 MAIN INSTALLATION BETWEEN DRAINAGE INLET AND SIDEWALK
- W-17 TROUGH FRAME PEDESTRIAN LOADING SINGLE DOOR
- W-18 TROUGH FRAME PEDESTRIAN LOADING DOUBLE DOOR
- W-19 ACCESS DOOR CROSS REFERENCE CHART
- W-20 TEMPORARY JUMPER CONNECTION
- W-21 CONTRACTORS' INSTALLATION REQUIRMENTS FOR A 2" TEMPORARY METER
- W-22 POTABLE WATER DESIGN AND CONSTRUCTION NOTES
- W-23 POTABLE WATER DESIGN AND CONSTRUCTION NOTES
- W-24 POTABLE WATER DESIGN AND CONSTRUCTION NOTES
- W-25 TECHNICAL SPECIFICATIONS FOR MECHANICAL JOINT DUCTILE IRON PIPE FITTINGS
- W-26 VALVE BOX SINGLE AND DOUBLE SERVICE



STANDARD CONSTRUCTION DETAIL
INDEX
WATER DETAILS

FILE NAME:

WTRINDEX.DWG

DETAIL REF:

INDEX

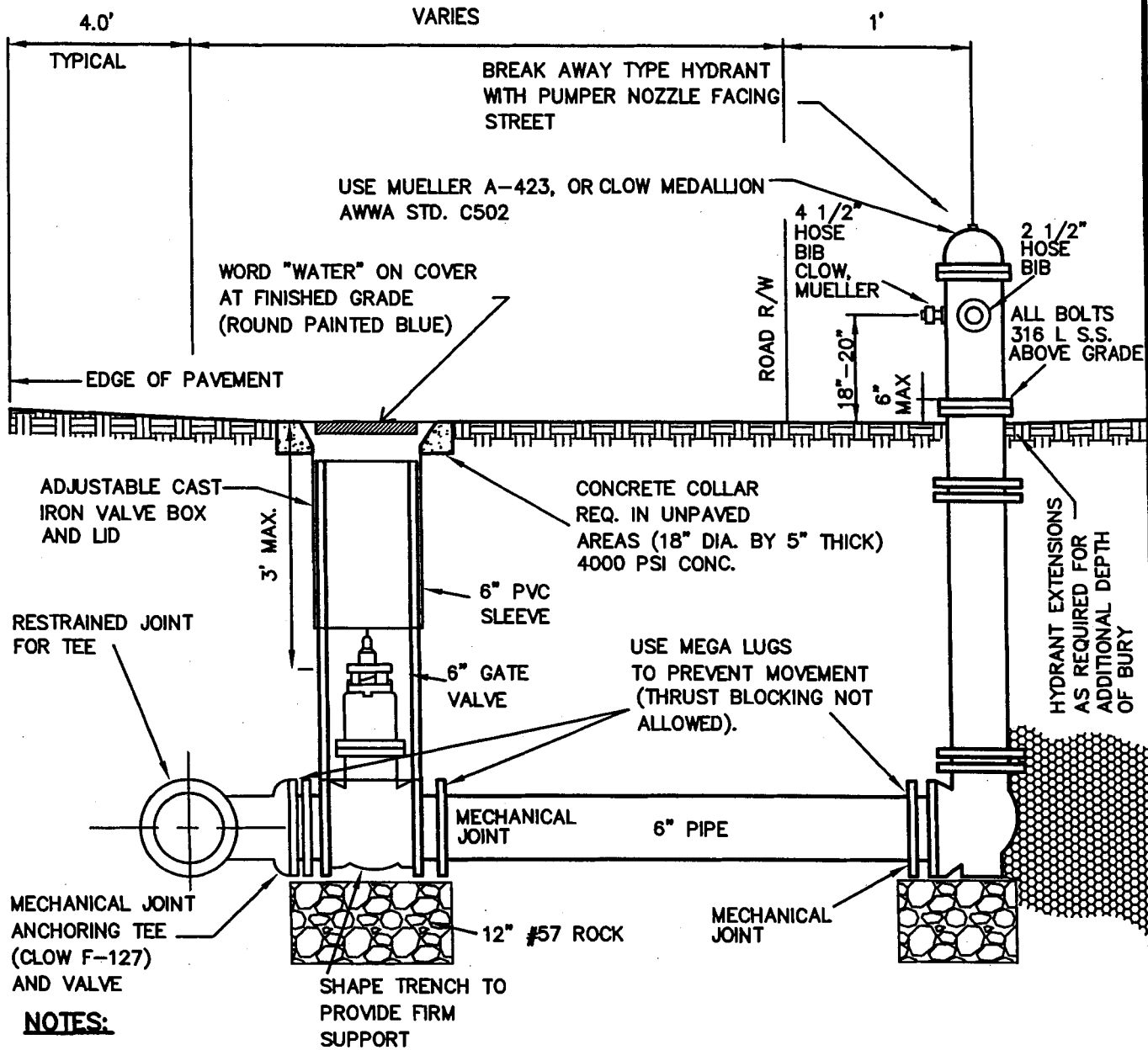

NOTES:

1. HYDRANTS TO BE PAINTED RED.
2. HOSE BIBS TO BE AMERICAN STANDARD THREADS. (FIRE THREAD)
3. RESTRAINED JOINTS REQUIRED. THRUST BLOCKS ARE NOT PERMITTED.
4. ADJUSTABLE TRENCH ADAPTOR ASSY. REQUIRED FOR ALL VALVES GREATER THAN 3' DEEP.
5. INSTALL AT SIDE LOT LINES OR AT CORNERS OF ROADWAY INTERSECTIONS, (TYPICAL)
6. BLUE REFLECTORS TO BE PLACED IN MIDDLE OF TRAVEL LANE ON SIDE OF ROAD THE HYDRANT IS ON.



**STANDARD CONSTRUCTION DETAIL
FIRE HYDRANT ASSEMBLY**

FILE NAME:

EW_W1.DWG

DETAIL REF:

W-1

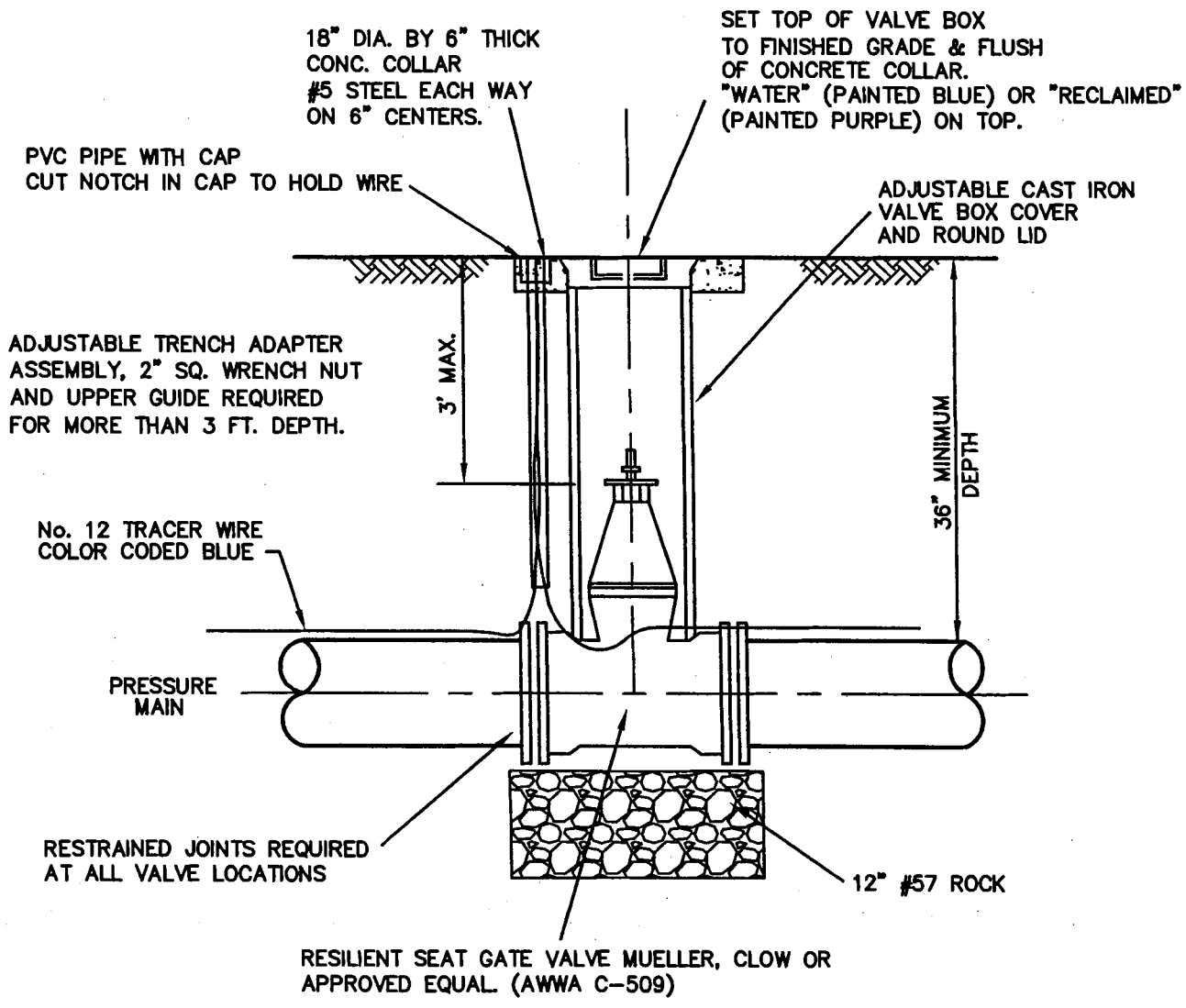

NOTE:

1. ROD OR BOLT TEE WHERE APPLICABLE.
2. VALVE BOX EXTENSIONS SHALL BE ONE CONTINUOUS PIECE OF PIPE.



**STANDARD CONSTRUCTION DETAIL
POTABLE WATER AND/OR RECLAIMED WATER
VALVE AND VALVE BOX
(2" - 16" VALVE SIZES)**

FILE NAME:

EW_W2.DWG

DETAIL REF:

W-2

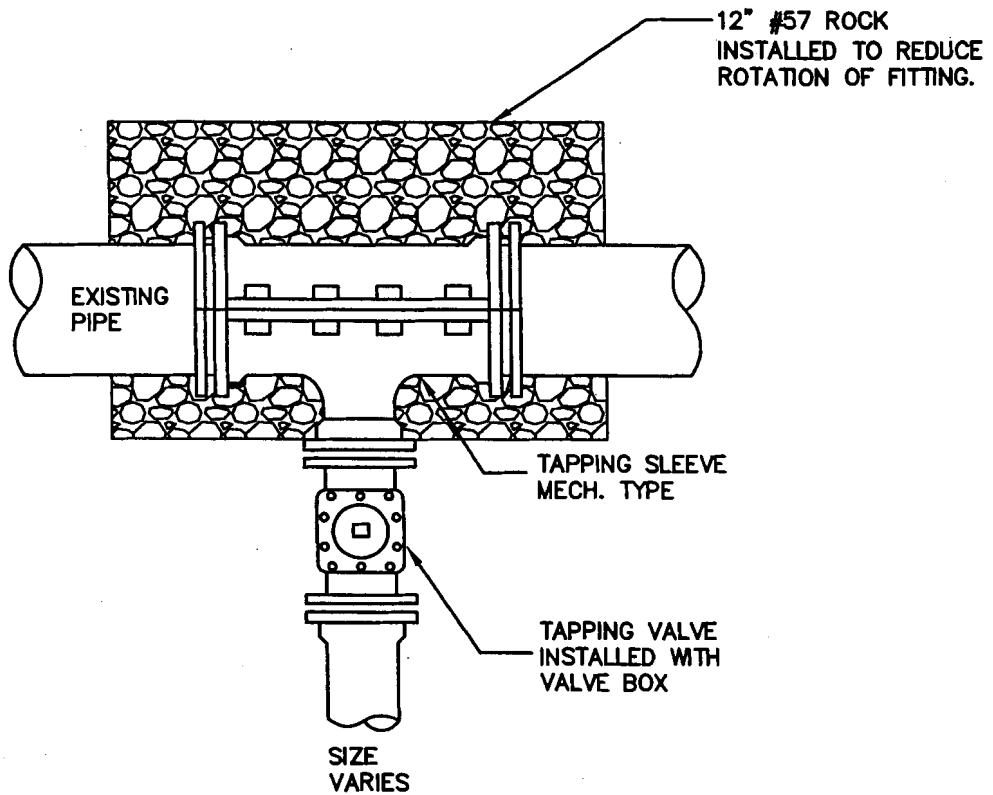

NOTES:

1. TAPPING SLEEVES SHALL BE ALL STAINLESS STEEL i.e. ROMAC INDUSTRIES, INC. MODEL SST.
2. INSTALL REQUIRED RESTRAINED JOINTS. IN NO INSTANCE SHALL THRUST BLOCK BE PERMITTED.
3. ALL TAPPING OF MAINS SHALL BE SUPERVISED BY THE CITY 48 HRS ADVANCE NOTICE PROVIDED.
4. TAPPING ASSEMBLY TO BE TESTED AT 150 p.s.i. FOR 10 MINUTES PRIOR TO PERFORMING TAP.



**STANDARD CONSTRUCTION DETAIL
TAPPING VALVE AND SLEEVE**

FILE NAME:

EW_W3.DWG

DETAIL REF:

W-3

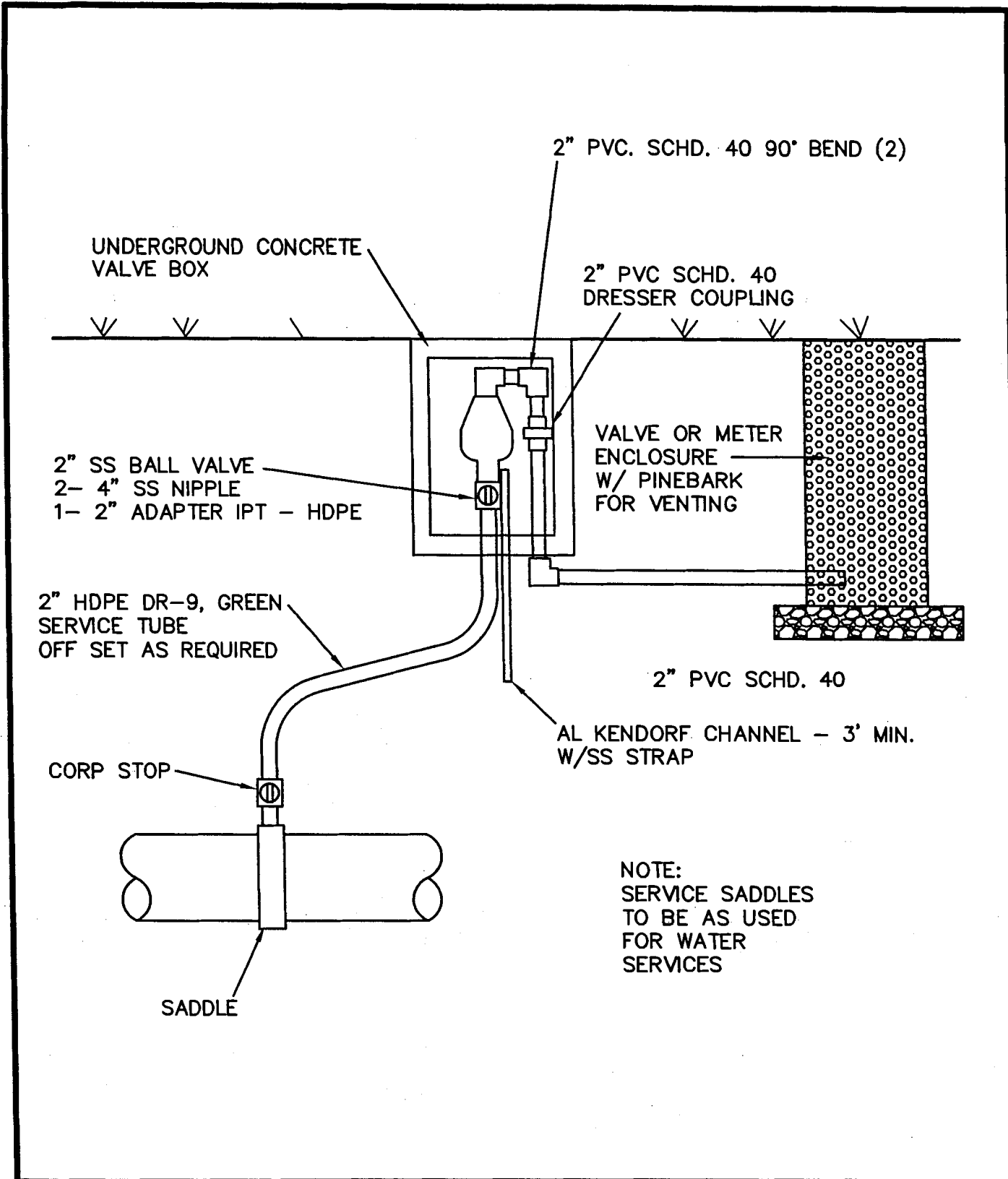

STANDARD CONSTRUCTION DETAIL
AIR / VACUUM RELEASE VALVE PIT

FILE NAME:

EW_W4.DWG

DETAIL REF:

W-4

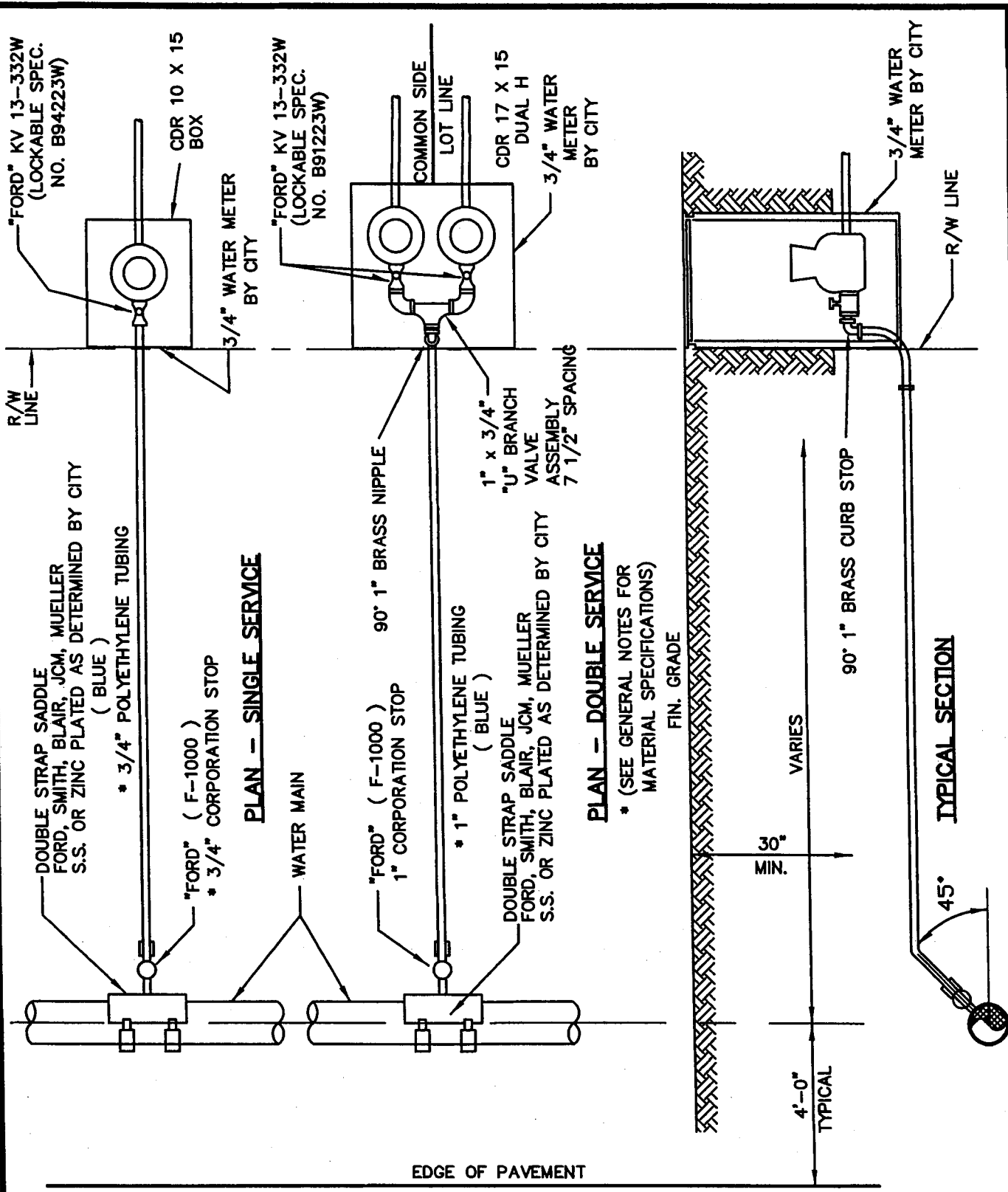

PLAN - DOUBLE SERVICE
 * (SEE GENERAL NOTES FOR MATERIAL SPECIFICATIONS)



STANDARD CONSTRUCTION DETAIL
WATER LATERAL SERVICE
 (3/4" - 2" SIZES)

FILE NAME:	EW_W5.DWG
DETAIL REF:	W-5

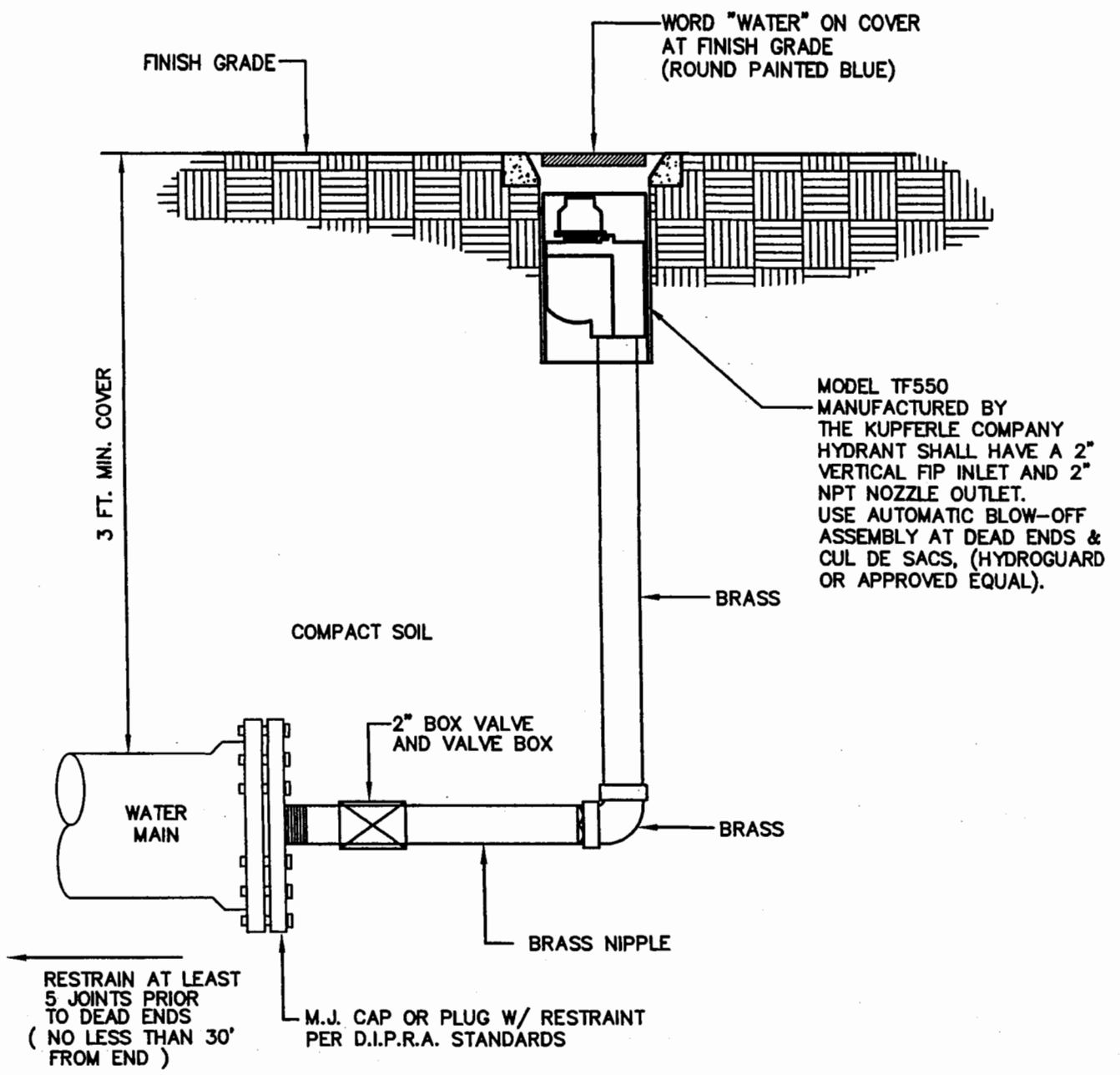

NOTES:

- 1. NO GALVANIZED FITTINGS PERMITTED.



**STANDARD CONSTRUCTION DETAIL
POTABLE WATER
BLOW-OFF ASSEMBLY**

FILE NAME:	EW_W6.DWG
DETAIL REF:	W-6

SPLIT RING
RETAINER GLAND

DIP RESTRAINED JOINT
SLEEVE

C-900 PVC
MAIN

H.D.P.E. MAIN
SDR 11

RESTRAIN PER DIPRA STANDARDS
FOR POLYETHYLENE ENCASED PIPE
AND 150 PSI DESIGN PRESSURE



STANDARD CONSTRUCTION DETAIL
P.V.C. TO H.D.P.E.
RESTRAINED JOINT DETAIL

FILE NAME:

EW_W7.DWG

DETAIL REF:

W-7

(2) 4" DIAM. STEEL
PIPES, CONC. FILLED
PAINTED YELLOW

(2) 1/4"+ "ENGINEERED"
HINGED ALUM. PLATE COVERS
ANCHORED TO STRUCTURE
SHALL BE USFAPD ALUMINUM
HATCH OR EQUAL WITH 300 LB./FT.
PEDESTRIAN LOADING WITH DRAIN
TO OUTSIDE PER W-17 THRU W-19.

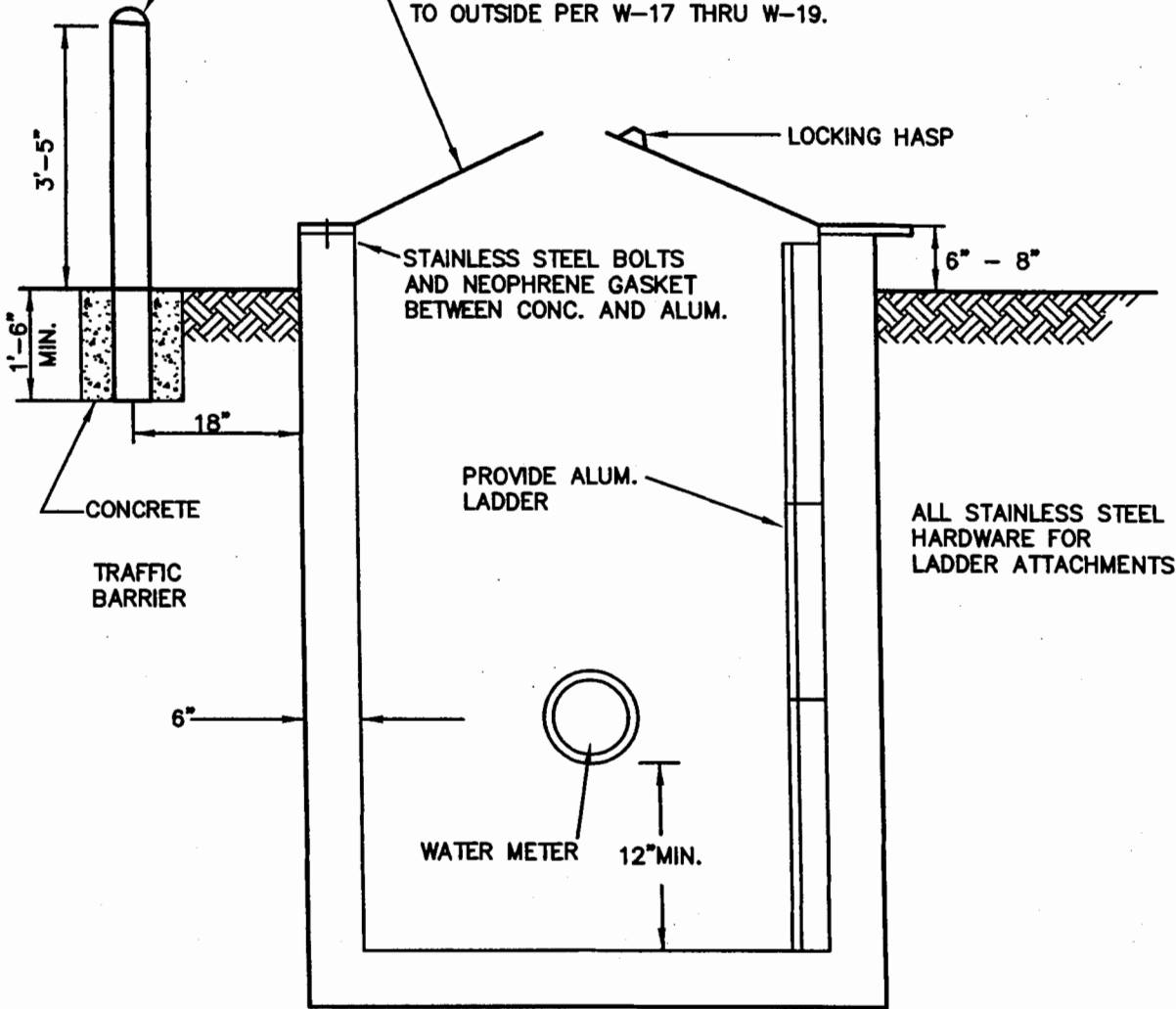

NOTES:

1. BOX SHOULD BE SIZED TO MATCH PROPOSED METER SIZE REQUIREMENTS.
2. VERIFY ACTUAL METER BOX DIMENSIONS WITH CITY PRIOR TO ORDERING AND/OR INSTALLATION.



**STANDARD CONSTRUCTION DETAIL
WATER METER BOX
(METER 3" AND LARGER SIZES)**

FILE NAME:

EW_W8.DWG

DETAIL REF:

W-8

METER		MINIMUM (INCHES) METER BOX SIZES			BROOKS EQUIVALENT
TYPE	SIZE	A	B	C	
TURBINE	3"	60	48	60	SERIES 666 W/6" FLOOR
	4"	60	48	60	"
	6"	60	60	60	"
	8"	60	60	60	"
COMPOUND	3"	60	48	66	"
	4"	60	48	66	"
	6"	60	60	72	"
	8"	60	60	72	"
F.M.	3"	72	48	60	"
	4"	72	48	60	"
	6"	78	66	60	M-88 SERIES W/6" FLOOR & 12" COVER
	8"	84	72	66	

NOTE:

1. VERIFY ACTUAL METER BOX SIZE WITH CITY PRIOR TO ORDERING.
2. METERS TO BE RADIO-REED, BY INVENSYS.



STANDARD CONSTRUCTION DETAIL
3" - 8" WATER METER BOX

FILE NAME:

EW_W9.DWG

DETAIL REF:

W-9

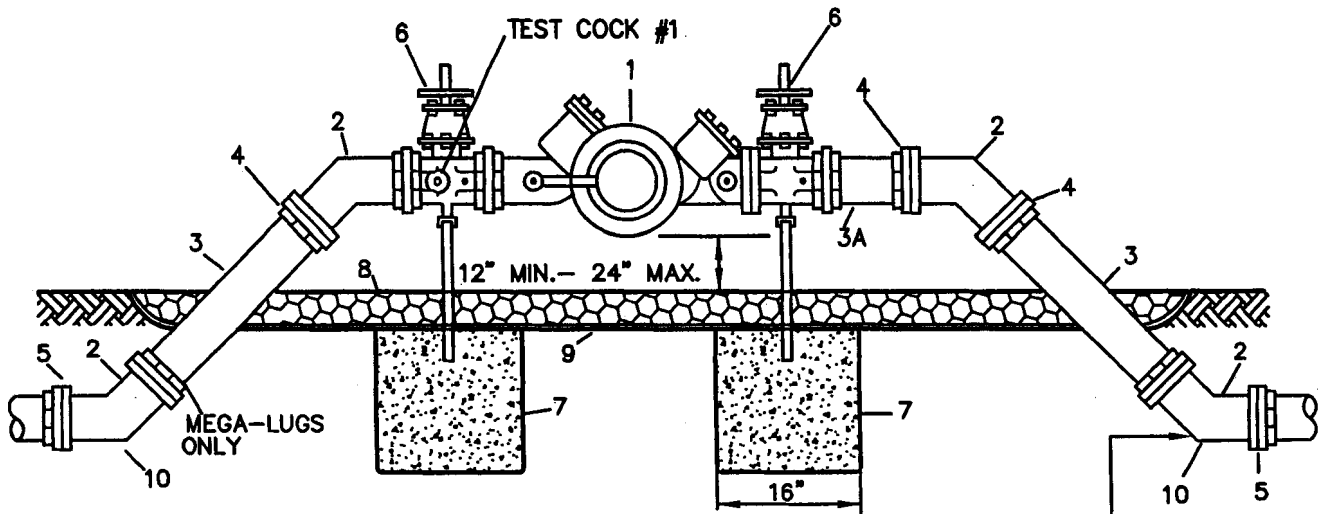

**REDUCED PRESSURE
BACKFLOW PREVENTER
SINGLE SERVICE: 3" - 8"**

ALL 45° BENDS
CAN BE REPLACED
WITH 90° BENDS

M A T E R I A L S		
ITEM	QUANT.	DESCRIPTION
1	1	3", 8" VALVE, REDUCED PRESSURE PRINCIPLE
2	4	3", 8" BEND - 45°
3	2	3", 8" ADAPTER, C.I. F - PE
3A	1	3", 8" ADAPTER, C.I. F - PE (OPT.)
4	3	3", 8" ADAPTER FLANGE D.I.P.
5	2	3", 8" ADAPTER FLANGE P.V.C. (DR - 18)
6	2	3", 8" VALVE, GATE, C.I., F-F
7	1 or 2	2" IRON PIPE/CONCRETE FOUNDATION
8	*	PEA GRAVEL
9	*	PLASTIC LINER
10	2	MJ 45° OR 90° MEGALUG OR RESTRAINED JOINT

NOTES:

1. FIELD ADJUST AND CUT ITEM 3 TO THE PROPER LENGTH.
2. DO NOT INTERCHANGE ITEMS 4 AND 5.
3. ALL COMMERCIAL PROPERTIES ARE REQUIRED BY ORDINANCE TO HAVE A BACKFLOW DEVICE INSTALLED AND ANNUALLY TESTED WITH PASSING RESULTS FORWARDED TO THE CITY ENVIRONMENTAL SERVICES DEPARTMENT.



**STANDARD CONSTRUCTION DETAIL
BACKFLOW PREVENTER
(REDUCED PRESSURE) 3" - 8"**

FILE NAME:

EW_W10.DWG

DETAIL REF:

W-10

**DOUBLE CHECK OR REDUCED PRESSURE
BACKFLOW PREVENTER
SINGLE SERVICE: 3/4", 1", 1-1/2", 2"**

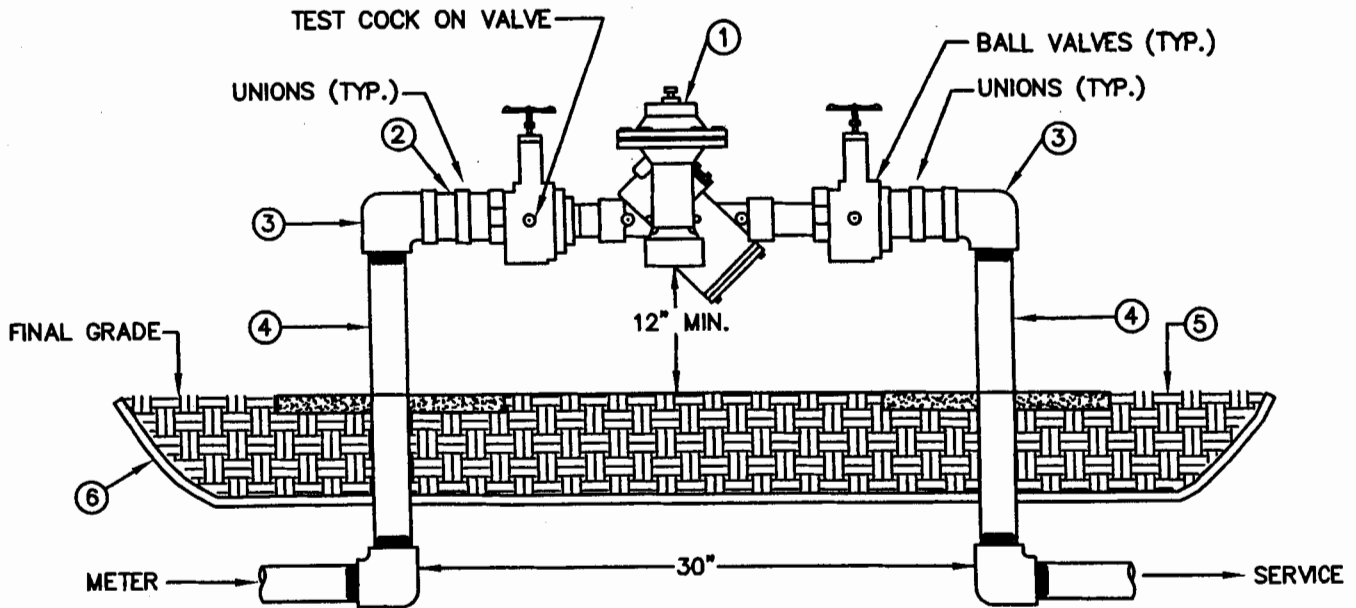

MATERIALS

ITEM	QUANT.	DESCRIPTION
1.	1	2" BACKFLOW PREVENTER ASSEMBLY
2.	2	2" X NOM. NIPPLES - BRASS
3.	2	2" X 90° ELBOWS - GALV. / HARD COPPER
4.	2	2" X VARIES RISER - GALV. / HARD COPPER
5.	*	PEA GRAVEL
6.	*	PLASTIC LINER

NOTES:

1. INSTALLATION SHOWN ABOVE IS FOR A 2" SERVICE. CHANGE PIPING MATERIALS ACCORDINGLY FOR SERVICE SIZE.
2. CONTACT ADMINISTRATION OFFICE AT 424-2460 FOR LIST OF APPROVED DEVICES.



**STANDARD CONSTRUCTION DETAIL
2" BACKFLOW PREVENTER**

FILE NAME:

EW_W11.DWG

DETAIL REF:

W-11

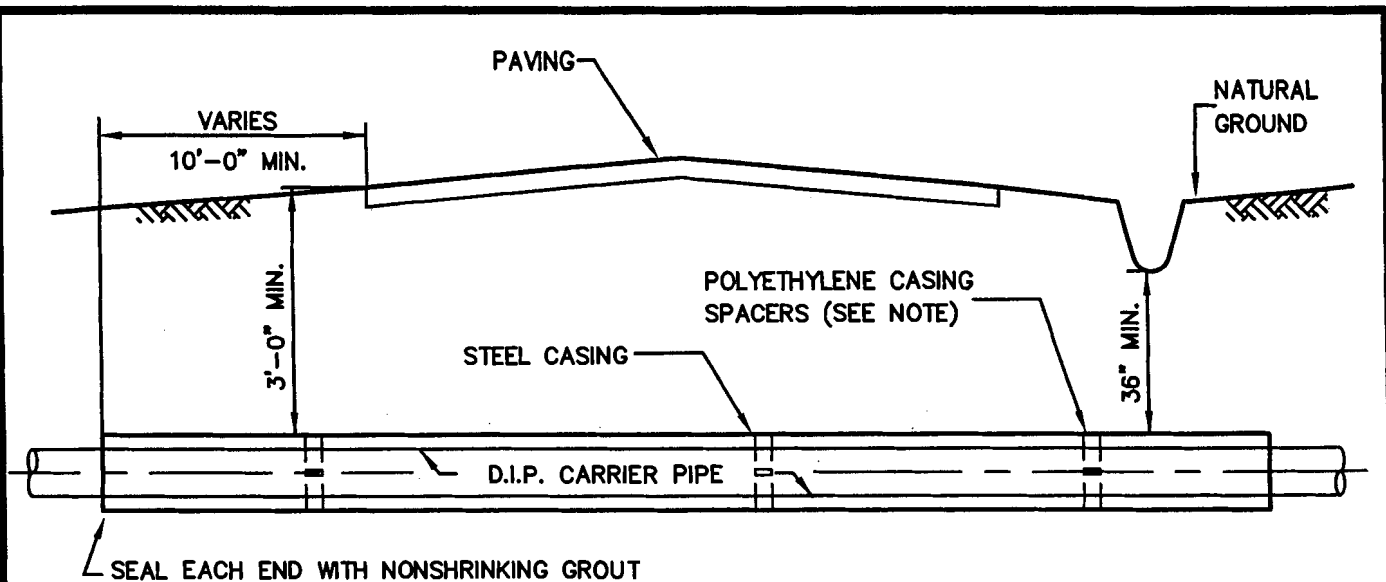

NOTES:

1. MINIMUM COVER FOR TOP OF CASING ON ALL CITY STREETS SHALL BE 3.0'
2. CASING FOR F.E.C. CROSSINGS SHALL BE INSTALLED IN ACCORDANCE WITH F.E.C. REQUIREMENTS.
3. FOR MINIMUM COVER ON ALL STATE AND COUNTY ROADS WITHIN THE CITY LIMITS PLEASE REFER TO THEIR RESPECTIVE AUTHORITIES.
4. THE INSIDE DIAMETER OF THE CASING PIPE SHALL BE A MINIMUM OF 4 INCHES GREATER THAN THE OUTSIDE DIAMETER OF THE CARRIER PIPE BELL OR COUPLING.
5. USE POLYETHYLENE CASING SPACERS FOR ALL CARRIER PIPES PER MANUFACTURES RECOMMENDATIONS.
6. ROTATION OF CARRIER PIPE INSIDE THE CASING PIPE WILL NOT BE PERMITTED. MECHANICAL OR FLANGED JOINT PIPE SHALL BE USED TO HELP PREVENT SUCH ROTATION.
7. THE CONTRACTOR SHALL SUBMIT SHOP DRAWINGS OF CASING AND CARRIER PIPE INSTALLATION FOR APPROVAL PRIOR TO FABRICATION OF PIPING, CASING, AND APPURTENANCES. CERTIFICATION OF CASING PIPE IS REQUIRED.
8. GROUTING OF SPACE BETWEEN CASING AND CARRIER PIPE REQUIRED UNLESS NEGATIVE FLOTATION EXISTS.
9. WELDING OF CASING PIPE TO BE DONE BY CERTIFIED WELDER. ALL ENDS OF CASING PIPE SHALL BE CHAMFERED PRIOR TO ANY WELDING.
10. SEALING END OF CASING PIPE WITH CONCRETE IS ALSO PERMISSIBLE.
11. CARRIER PIPE SHALL BE RESTRAINED JOINT THROUGH ENTIRE LENGTH OF CASING PIPE.
12. FOR GRAVITY CARRIER PIPE SYSTEM, ENTIRE ANNULAR SPACE BETWEEN CARRIER PIPE AND CASING PIPE SHALL BE GROUTED.



**STANDARD CONSTRUCTION DETAIL
CONDUIT CROSSING R.R. OR ROADWAY**

FILE NAME:

EW_W12.DWG

DETAIL REF:

W-12

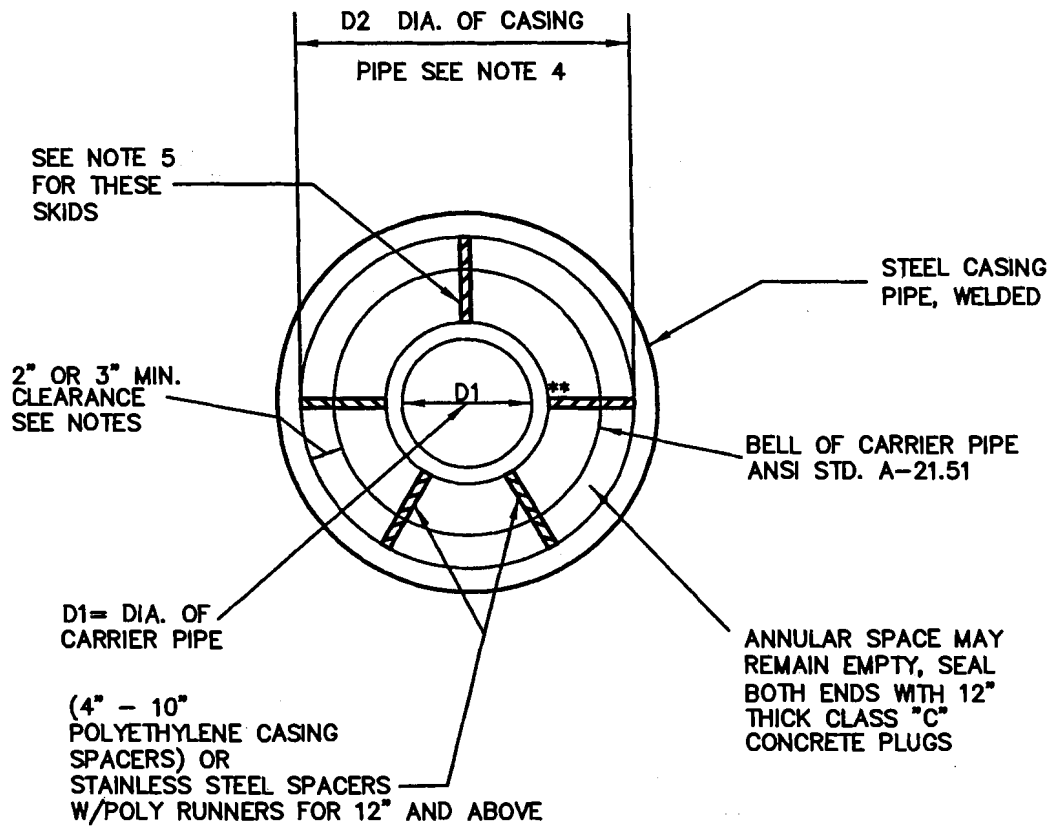

CARRIER PIPE AND CASING PIPE SIZES (MIN.)														
CARRIER PIPE NOM. DIA. (D1)	4	6	8	10	12	14	16	18	20	24	30	36	42	48
CASING PIPE NOM. DIA. (D2)	14	16	18	22	24	30	30	30	36	36	48	54	60	66
WALL THICKNESS—INCHES (NOTES 4&5)	PER AUTHORITY HAVING JURISDICTION													

NOTES:

1. THE CONTRACTOR SHALL SUBMIT SHOP DRAWINGS OF CASING INSTALLATION TO ENGINEER FOR REVIEW PRIOR TO INSTALLATION
2. SEAL BOTH ENDS OF CASING W/ 12" BRICK AND NON-SHRINK GROUT (MINIMUM)
3. ROTATION OF CARRIER PIPE INSIDE THE CASING WILL NOT BE PERMITTED
4. WITHIN EDGEWATER R/W USE CURRENT FDOT STANDARDS
5. SPECIALLY DESIGNED SPACERS MAY BE USED IN ACCORDANCE WITH MANUFACTURER'S SPECIFICATIONS.



**STANDARD CONSTRUCTION DETAIL
CONDUIT CROSSING R.R. OR ROADWAY**

FILE NAME:

EW_W13.DWG

DETAIL REF:

W-13

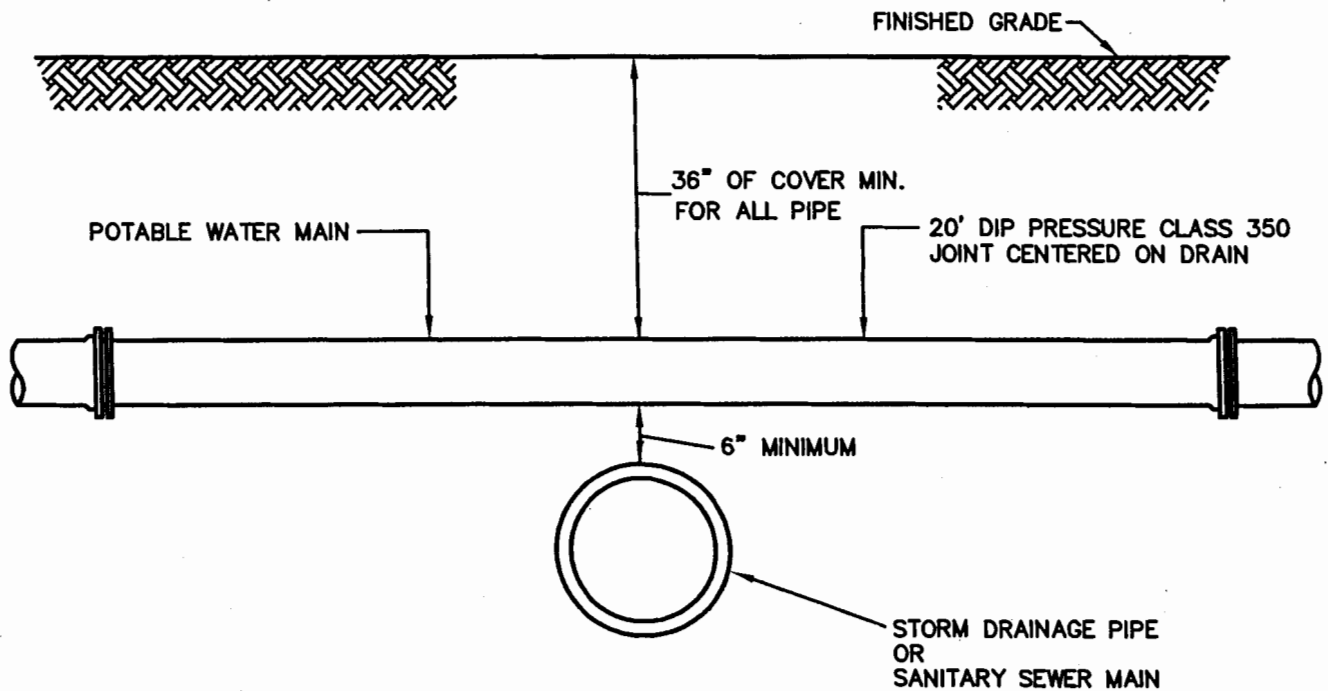

NOTE:

1. CONCRETE ENCASUREMENT OF A SANITARY SEWER MAIN IS AN ALTERNATIVE METHOD OF ADDRESSING A CONFLICT WHEN 18" VERTICAL SEPARATION DISTANCE CANNOT BE MAINTAINED. IN SUCH INSTANCES, THE MINIMUM PIPE VERTICAL SEPARATION SHALL BE 6".



**STANDARD CONSTRUCTION DETAIL
STORM DRAINAGE PIPE
OR SANITARY SEWER MAIN CONFLICT**

FILE NAME:

EW_W14.DWG

DETAIL REF:

W-14

CONCRETE ENCASEMENT OF SANITARY SEWER IS AN ALTERNATIVE METHOD OF ADDRESSING A CONFLICT WHEN UNABLE TO MAINTAIN 18" VERTICAL SEPARATION DISTANCE. IN SUCH INSTANCES, THE MINIMUM PIPE VERTICAL SEPARATION SHALL BE 6".

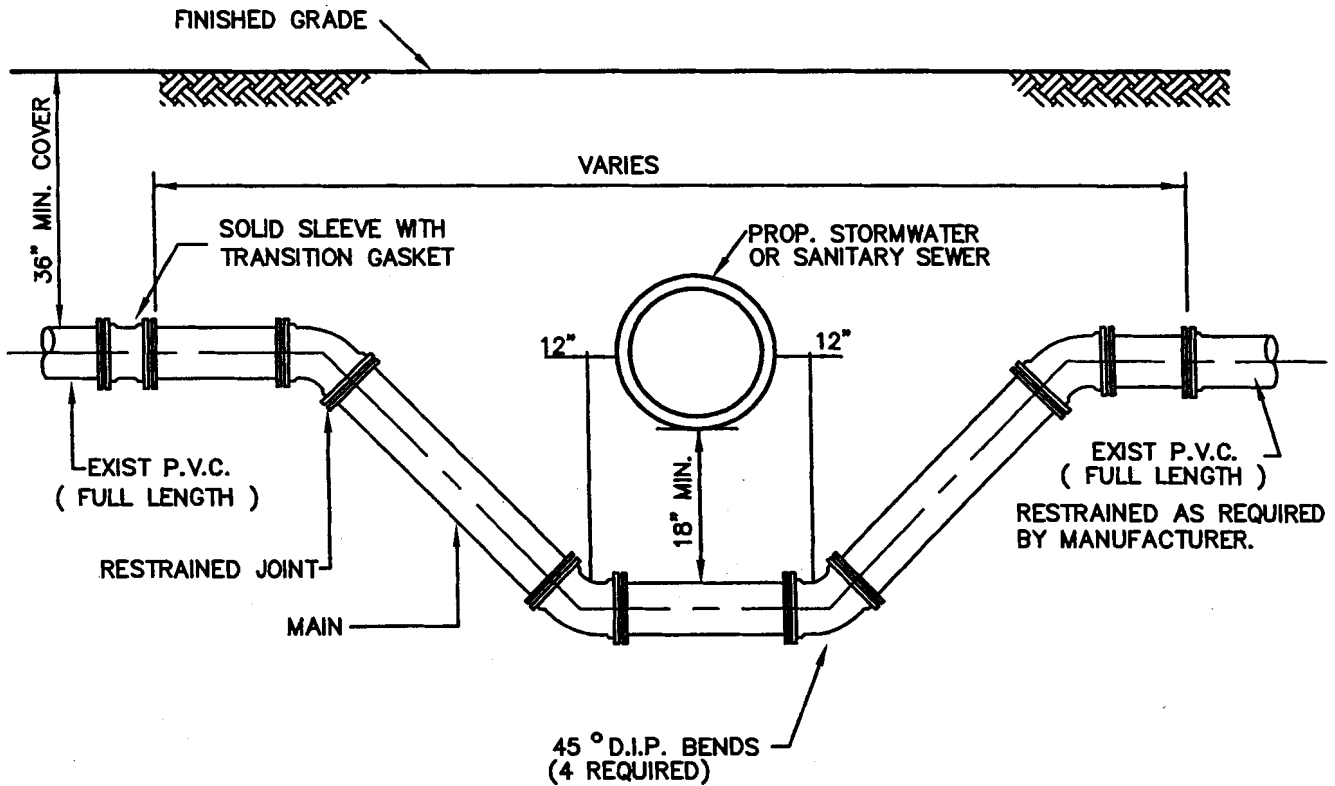

NOTES:

1. LOWERING OF EXISTING WATER MAIN & FORCE MAIN BY DEFLECTION METHOD ACCEPTABLE IF EXISTING FIELD CONDITIONS PERMIT.
2. LENGTH OF SECTION BASED ON MINIMUM LENGTH AS DETERMINED BY DIPRA RESTRAINED JOINT MANUAL.
3. INSTALL RESTRAINED JOINTS, AS REQUIRED, FROM DEFLECTION POINT IN BOTH DIRECTIONS.



STANDARD CONSTRUCTION DETAIL
STORM DRAINAGE PIPE
OR SANITARY SEWER MAIN
CONFLICT

FILE NAME:

EW_W15.DWG

DETAIL REF:

W-15

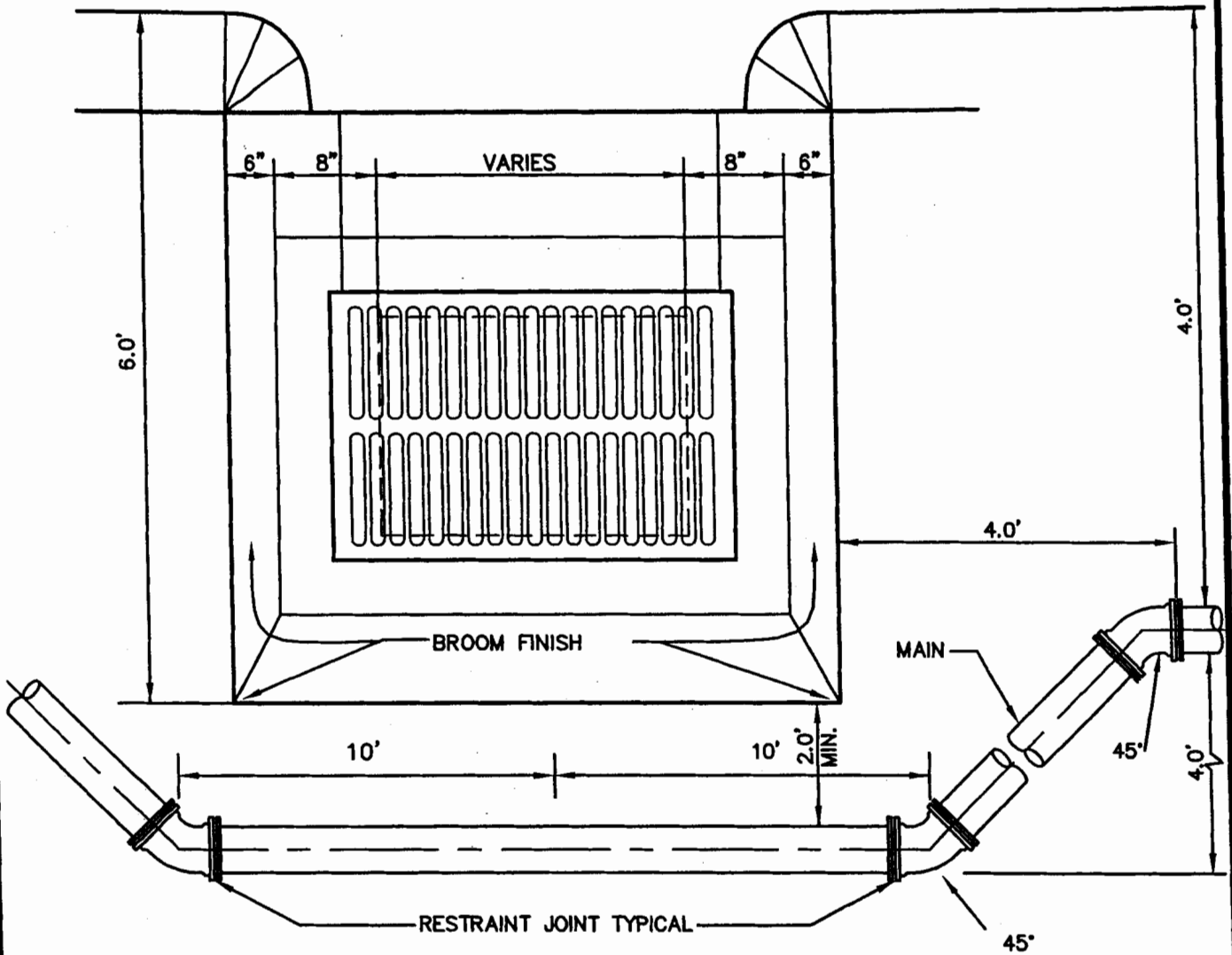

NOTES:

1. MAIN MAY PASS OVER STORM LINE IF 36" OF COVER IS PROVIDED OVER WATER MAIN OR RECLAIMED WATER LINE AND ADEQUATE CLEARANCE IS PROVIDED FROM THE STORM SEWER PIPE.
2. PIPE SHALL BE DEFLECTED AROUND DRAINAGE INLET IN ACCORDANCE WITH THE RESTRAINED JOINT GUIDELINES OF THE DIPRA AND ADAPTED TO PVC PIPE AS NECESSARY.



**STANDARD CONSTRUCTION DETAIL
MAIN INSTALLATION BETWEEN
DRAINAGE INLET AND SIDEWALK**

FILE NAME:

EW_W16.DWG

DETAIL REF:

W-16

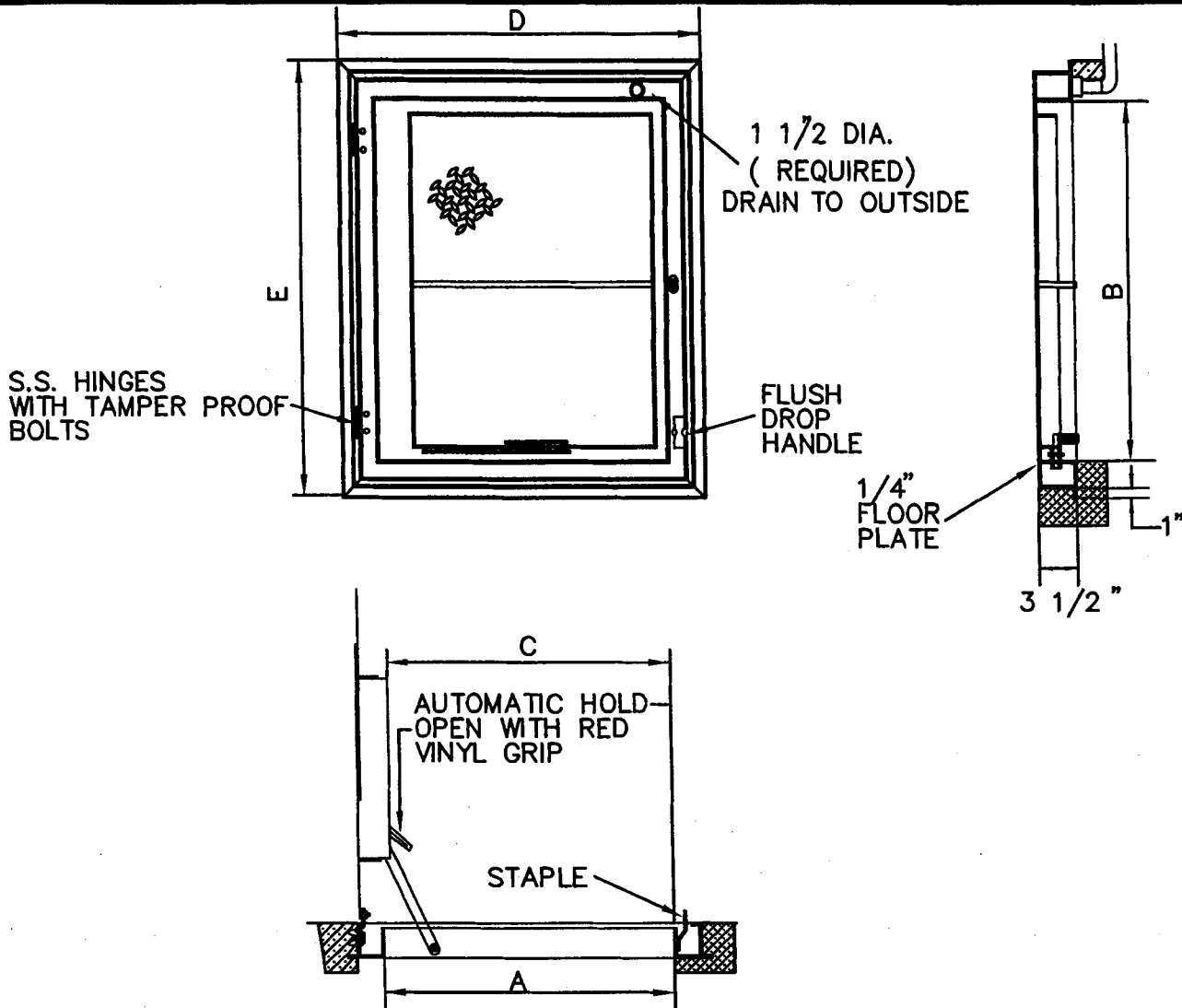

300 P.S.F. LOADING

TYPE	MAT'L THK	SIZE		ACTUAL OPEN.		OVERALL SIZE		WEIGHT LBS.
		A	B	A	C	D	E	
TPS	1/4	24	24	24	24	32	32	60
TPS	1/4	24	30	24	30	32	38	70
TPS	1/4	24	36	23	36	32	44	75
TPS	1/4	30	30	29	30	38	38	80
TPS	1/4	30	36	29	36	38	44	90
TPS	1/4	30	48	29	48	38	56	105
TPS	1/4	36	36	34	36	44	44	100
TPS	1/4	36	48	34	48	44	56	120
TPS	1/4	42	42	40	42	50	50	125

NOTES:

- HATCH MATERIAL SHALL BE ALUMINUM WITH STAINLESS STEEL BOLTS, NUTS AND HINGES, LOAD RATING OF 300 LBS PER SQ. FOOT WITH A SELF DRAINING HATCH.
- THE ACCESS DOOR SHALL BE TYPE TPS AS MANUFACTURED BY U.S. FOUNDRY AND MANUFACTURING CORP., MIAMI, FLORIDA.



**STANDARD CONSTRUCTION DETAIL
TROUGH FRAME PEDESTRIAN LOADING
SINGLE DOOR**

FILE NAME:
EW_W17.DWG

DETAIL REF:
W-17

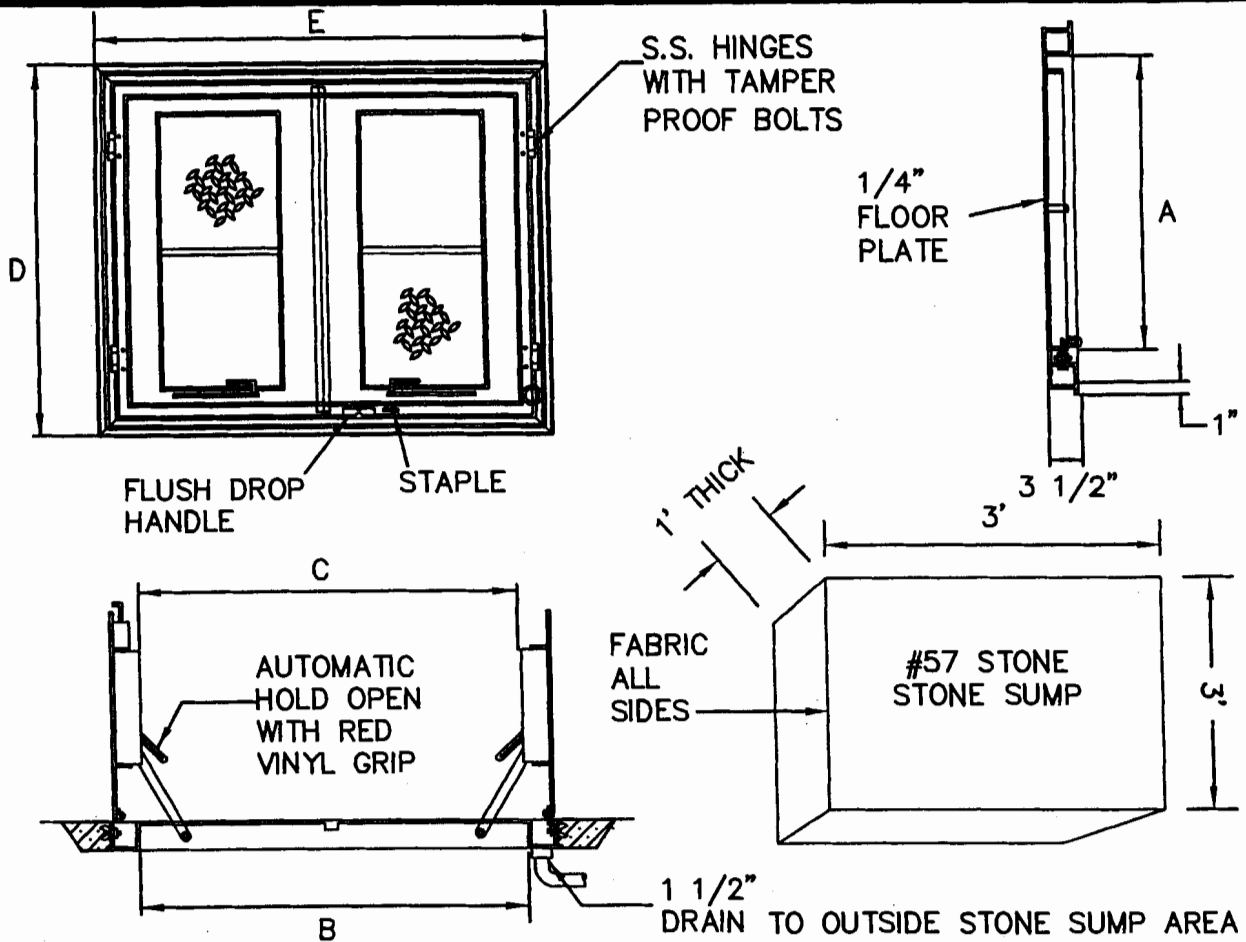

300 P.S.F. LOADING

TYPE	MAT'L THK	SIZE		ACTUAL OPENING		OVERALL SIZE		WEIGHT LBS.
		A	B	A	C	D	E	
TPD	1/4	30	48	30	47	38	56	110
TPD	1/4	30	54	30	53	38	62	120
TPD	1/4	36	48	36	46	44	44	125
TPD	1/4	36	60	36	57	44	68	145
TPD	1/4	42	48	42	45	50	56	140
TPD	1/4	48	48	48	44	56	56	155
TPD	1/4	48	54	48	50	56	62	165
TPD	1/4	48	72	48	66	56	80	210
TPD	1/4	60	60	60	56	68	68	220

NOTES:

- HATCH MATERIAL SHALL BE ALUMINUM WITH STAINLESS STEEL BOLTS, NUTS AND HINGES, LOAD RATING OF 300 LBS. PER SQ. FOOT WITH A SELF DRAINING HATCH.
- THE ACCESS DOOR SHALL BE TYPE TPS AS MANUFACTURED BY U.S. FOUNDRY AND MANUFACTURING CORP., MIAMI, FLORIDA.



**STANDARD CONSTRUCTION DETAIL
TROUGH FRAME PEDESTRIAN LOADING
DOUBLE DOOR**

FILE NAME:

EW_W18.DWG

DETAIL REF:

W-18

U.S. FOUNDRY MODEL NO.	BILCO MODEL NO	SINGLE LEAF	DOUBLE LEAF	ALUMINUM	TROUGH
TPS 24X24 W/OP	J-1AL	*		*	*
TPS 30X30 W/OP	J-2AL	*		*	*
TPS 30X36 W/OP	J-3AL	*		*	*
TPS 36X36 W/OP	J-4AL	*		*	*
TPS 42X42 W/OP	J-5AL			*	*
TPD 48X48 W/OP	JD-2AL		*	*	*
TPD 48X72 W/OP	JD-3AL		*	*	*
TPD 60X60 W/OP	JD-4AL		*	*	*



STANDARD CONSTRUCTION DETAIL
ACCESS DOOR
CROSS REFERENCE CHART

FILE NAME:

EW_W19.DWG

DETAIL REF:

W-19

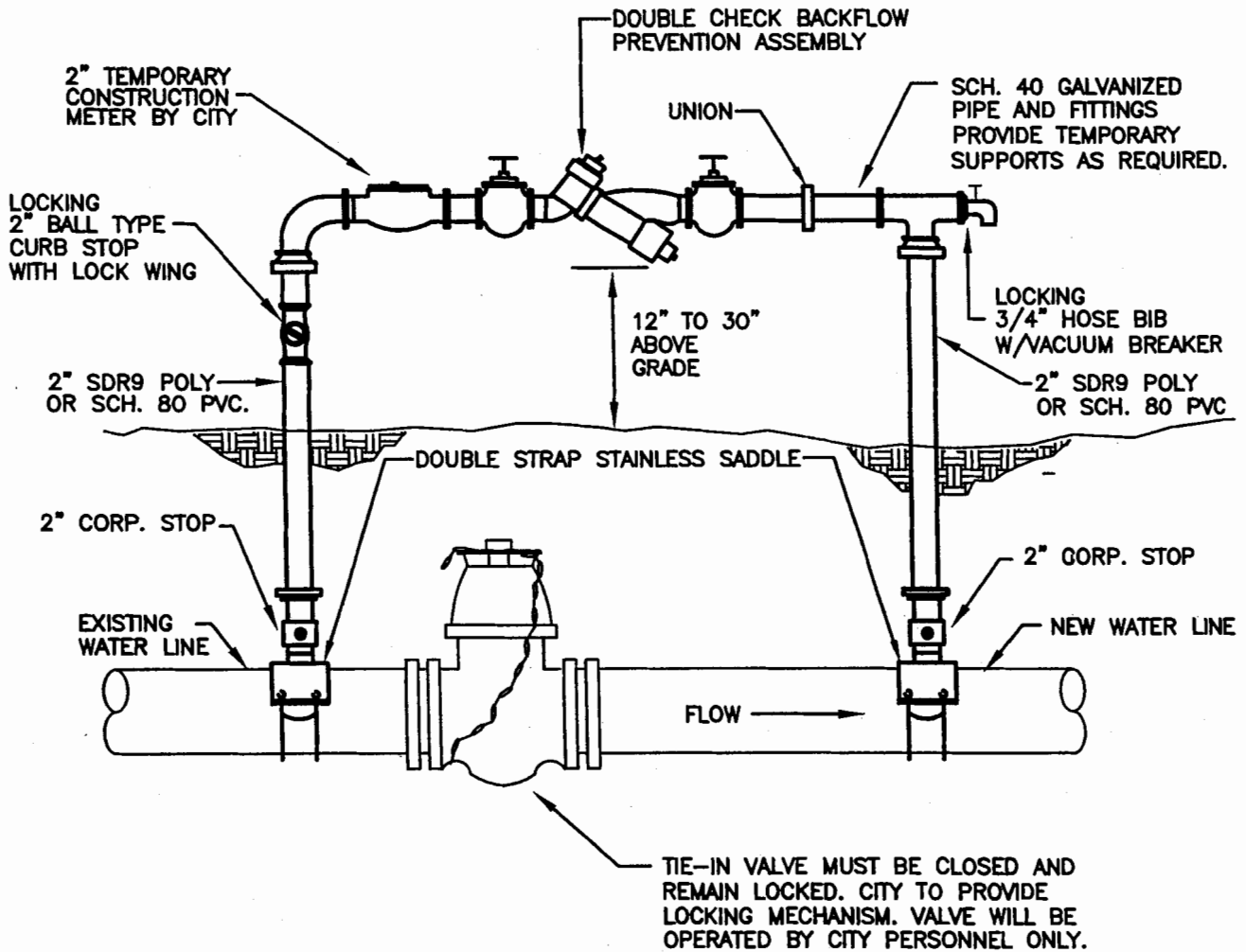

NOTES:

1. PROVIDE SUPPORT AND/OR PROTECTIVE MEASURES TO PREVENT ABOVE GROUND PIPE BEING BROKEN.



**STANDARD CONSTRUCTION DETAIL
TEMPORARY JUMPER CONNECTION**

FILE NAME:

EW_W20.DWG

DETAIL REF:

W-20

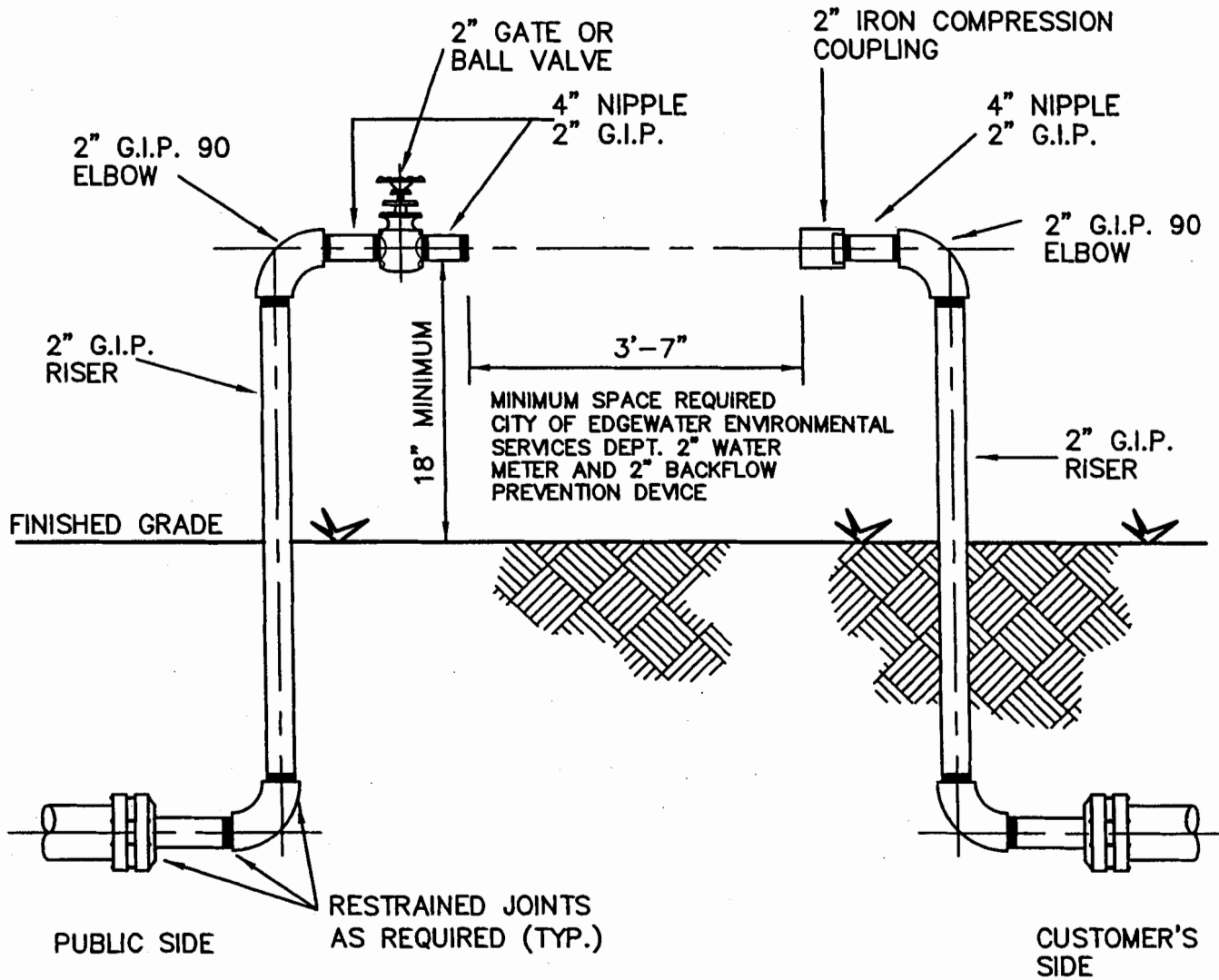

NOTE:

1. PROVIDE SUPPORT OR PROTECTIVE POSTS.



**STANDARD CONSTRUCTION DETAIL
CONTRACTORS' INSTALLATION REQUIREMENTS
FOR A 2" TEMPORARY METER**

FILE NAME:

EW_W21.DWG

DETAIL REF:

W-21

**POTABLE WATER DESIGN AND
CONSTRUCTION NOTES**

1. THE CITY'S PUBLIC UTILITIES DEPARTMENT (424-2460) SHALL BE GIVEN A MINIMUM OF 48 HOURS ADVANCE NOTICE (NOT INCLUDING HOLIDAYS OR WEEKENDS) PRIOR TO BEGINNING ANY POTABLE WATER SYSTEM CONSTRUCTION.
2. DEWATERING SHALL BE PROVIDED TO KEEP GROUNDWATER ELEVATION A MINIMUM OF 6 INCHES BELOW WATER MAIN BEING LAID
3. ALL WATER MAINS SHALL BE LAID ON A FIRM FOUNDATION WITH ALL UNSUITABLE MATERIAL (MUCK, ROCK, COQUINA, ETC.) REMOVED AND REPLACED WITH CLEAN GRANULAR MATERIAL.
4. TRENCHES SHALL BE BACKFILLED WITH MATERIAL ACCEPTABLE TO THE CITY WITH A MINIMUM COMPACTION OF 98% IN PAVED AREAS AND 95% IN UNPAVED AREAS IN ACCORDANCE WITH AASHTO T-180.
5. IT SHALL BE THE CONTRACTORS RESPONSIBILITY TO ENSURE THAT TRENCH COMPACTION TESTS BE PROVIDED AT POINTS 1 FOOT ABOVE THE PIPE AND AT 1 FOOT VERTICAL INTERVALS TO FINISH GRADE, AT A MINIMUM SPACING OF EVERY 300 FEET.
6. 3" METALLIZED PIPE LOCATION TAPE SHALL BE LOCATED BETWEEN 15" AND 24" BELOW FINISHED GRADE OR AS SPECIFIED BY MANUFACTURER FOR ALL PVC LINES. MARKER TAPE SHALL BE USED ON ALL DUCTILE IRON PIPE, AND 12 GAUGE TRACING WIRE AS WELL.
7. ALL SINGLE RESIDENTIAL WATER SERVICES SHALL BE 3/4", DOUBLE RESIDENTIAL SERVICES SHALL BE 1", AND COMMERCIAL SERVICES 1-1/2" OR 2". POLYETHYLENE TUBING SHALL BE USED, IN ACCORDANCE WITH THE FOLLOWING SPECIFICATIONS:
POLYETHYLENE TUBING SHALL BE CTS 3408 HIGH DENSITY TUBING, BLUE IN COLOR, AND RATED FOR A MINIMUM OF 200 P.S.I. WITH SDR OF 9 (CTS). THE TUBING SHALL HAVE A VIRGIN HIGH DENSITY POLYETHYLENE CENTER FOR WHICH THE MANUFACTURER SHALL FURNISH A CERTIFICATE OF PURITY. THE TUBING SHALL HAVE UV PROTECTION AND SHALL NOT BE AFFECTED BY DIRECT SUNLIGHT. THE TUBING SHALL COMPLY WITH OR EXCEED THE APPLICABLE STANDARDS OF A.S.T.M. D1248, D3350, D2239, D2737, N.S.F. 14 AND A.W.W.A. C901 AND SHALL COME WITH A LIFETIME WARRANTY.
ACCEPTABLE MANUFACTURERS: ENDOT ENDO PURE OR APPROVED EQUAL
8. ALL WATER SERVICE ENDINGS SHALL BE MARKED WITH A 2" X 4" LUMBER (PRESSURE TREATED) EXTENDING 4 FEET ABOVE GRADE, WITH WATER SERVICES SECURED 12" MAXIMUM ABOVE THE GROUND AND ANY "U" BRANCHES FOR DOUBLE SERVICES SHALL BE AT GROUND LEVEL. ALL SERVICES SHALL BE LOCKED.
9. WATER VALVES SHALL BE PLACED AT ALL STREET INTERSECTIONS AND AT MAXIMUM SPACINGS OF 750 FEET.
10. AT ALL WATER MAIN TEES AND CROSSES, VALVES SHALL BE INSTALLED ON ALL LEGS EXCEPT ONE.
11. APPROVED WATER VALVE TYPES ARE THE FOLLOWING:
 - A. RESILIENT SEAT GATE VALVES 24" DIAMETER AND SMALLER (AWWA C-509)
 - B. BUTTERFLY VALVES GREATER THAN 24" (AWWA C-504)
 - C. TAPPING VALVES WITH MECHANICAL TAPPING SLEEVE.
12. ALL WATER VALVES SHALL BE ADJUSTED TO FINISHED GRADE WITH CONCRETE COLLARS AND THE CAPS PAINTED BLUE TO MAKE THEM PLAINLY VISIBLE.
13. UPON FINAL ACCEPTANCE OF NEW WATER SYSTEMS, WATER VALVES SHALL BE COMPLETELY OPENED BY PUBLIC UTILITIES PERSONNEL. AT NO TIME SHALL CONTRACTOR OPERATE ANY EXISTING VALVES.
14. TYPICALLY, A MINIMUM OF ONE FIRE HYDRANT SHALL BE LOCATED AT EVERY INTERSECTION. OTHER FIRE HYDRANTS SHALL BE LOCATED SO AS TO PRODUCE A MAXIMUM 375 FEET HOSE LAY ALONG THE STREET FOR ALL RESIDENTIAL BUILDINGS.



**STANDARD CONSTRUCTION DETAIL
POTABLE WATER DESIGN AND
CONSTRUCTION NOTES**

FILE NAME:

EW_W22.DWG

DETAIL REF:

W-22

**POTABLE WATER DESIGN AND
CONSTRUCTION NOTES (CONTD.)**

15. ALL FIRE HYDRANTS SHALL BE CONSTRUCTED TO MAKE THEM EASILY ACCESSIBLE TO FIRE PERSONNEL IN CASE OF A FIRE. THE PRIMARY HYDRANT PORT SHOULD ALWAYS FACE THE STREET.
16. AS STANDARD PRACTICE, WATER MAINS SHALL BE INSTALLED 4 FEET OFF THE BACK OF CURB OR AS APPROVED BY THE CITY.
17. ALL WATER MAINS SHALL BE NSF-APPROVED FOR POTABLE WATER USE, AND SHALL HAVE A MINIMUM COVER OF 36 INCHES.
18. ALL PROPOSED WATER MAINS SHALL BE FLUSHED, DISINFECTED AND BACTERIOLOGICALLY CLEARED FOR SERVICE IN ACCORDANCE WITH THE LATEST AWWA STANDARDS AND THE FLORIDA DEPARTMENT OF ENVIRONMENTAL PROTECTION REQUIREMENTS.
19. WATER MAINS SHALL BE C-900 PVC OR C-905 CL 150 (COLOR "BLUE") OR D.I.P. PRESSURE CLASS 350 STANDARD CEMENT LINED UNLESS OTHERWISE APPROVED BY THE CITY.
20. UPON CONSTRUCTION COMPLETION AND ACCEPTANCE OF THE SYSTEM, IT SHALL BE THE DESIGN ENGINEER'S RESPONSIBILITY TO ENSURE THAT THE SYSTEM IS PROPERLY CERTIFIED AND ACCEPTED BY THE DEPARTMENT OF HEALTH AND AS-BUILTS ARE PROVIDED TO THE CITY PRIOR TO ANY USE OF THIS SYSTEM .
21. WATER DISTRIBUTION SYSTEM SHALL BE DESIGNED TO COMPLY WITH THE CITY'S FIRE (WATER) FLOW CODE.
22. IN AREAS WHERE RECLAIMED WATER IS NOT AVAILABLE THE CONTRACTOR SHALL BE REQUIRED TO (UPON SATISFACTORY COMPLETION OF THE PRESSURE TEST) TRANSFER THE WATER FROM THE POTABLE WATER LINES TO THE RECLAIMED WATER LINES FOR UTILIZATION IN THEIR PRESSURE TEST.
23. IN AREAS WHERE RECLAIMED WATER IS AVAILABLE, RECLAIMED WATER WILL BE UTILIZED IN THE PRESSURE TESTING OF NEW RECLAIMED WATER LINES.
24. ALL POTABLE WATER MAINS SHALL USE A THRUST RESTRAINT JOINT METHOD IN COMPLIANCE WITH THE DUCTILE IRON PIPE RESEARCH ASSOCIATION (DIPRA) GUIDELINES. IN THE EVENT THAT PVC FITTINGS ARE SPECIFIED, THE RESTRAINT SHALL BE MODIFIED IN ACCORDANCE WITH THE RECOMMENDED ADDITIONAL RESTRAINT LENGTH REQUIRED FOR PIPE WRAPPED WITH POLYETHYLENE.
25. MEGALUGS, BOLTLESS RESTRAINED JOINTS, GRIPPER GASKETS, OR STAR GRIPS SHALL BE USED ON ALL RESTRAINED JOINT INSTALLATIONS. MINIMUM DEPTH OF BURY ON PIPES NOT MEETING REQUIRED COVER REQUIREMENTS SHALL FOLLOW THE MOST RECENT DIPRA THRUST RESTRAINT DESIGN GUIDELINES.
26. GRIPPER RING GASKETS BY ROMAC AND OR STAR AU-GRIP MAY BE USED AS APPROPRIATE FOR RESTRAINING PRESSURE PIPE TO FITTINGS, VALVES, ETC.
27. WATER SYSTEMS SHALL BE PRESSURE TESTED AT 150 PSI STATIC PRESSURE FOR A PERIOD OF 4 HOURS PER AWWA STANDARDS.
28. ALL WATER SERVICES SHALL BE MARKED WITH AN "\/" SAW CUT INTO THE CURB AND METAL TABS SET INTO THE PAVEMENT.
29. ALL WATER VALVES SHALL BE MARKED WITH AN "X" SAW CUT INTO THE CURB AND METAL TABS SET INTO THE PAVEMENT. BLOW-OFFS SHALL BE MARKED SIMILARLY, AS WELL.
30. WATER SERVICES SHALL BE NORMALLY DOUBLE 1" SERVICES LOCATED AT SIDE LOT LINES. IN INSTANCES WHERE SERVICES NEED TO BE OFFSET, 3/4" SINGLE SERVICES SHALL BE SPECIFIED. THESE SERVICES MAY BE OFFSET A MAXIMUM OF 2.0' FROM SIDE LOT LINES.
31. ALL TAPPING OF MAINS SHALL BE SUPERVISED BY THE CITY SCHEDULING OF THESE CONNECTIONS SHALL REQUIRE A MINIMUM 48 HOUR NOTIFICATION (MEASURED ON NORMAL WORK DAYS) DIRECTED TO THE CITY'S DESIGNATED SITE INSPECTOR. THE CONNECTION SHALL BE SCHEDULED TO COMMENCE BETWEEN 8:00 A.M. AND NOON ON THE APPROPRIATE DAY.



**STANDARD CONSTRUCTION DETAIL
POTABLE WATER DESIGN AND
CONSTRUCTION NOTES**

FILE NAME:

EW_W23.DWG

DETAIL REF:

W-23

**POTABLE WATER DESIGN AND
CONSTRUCTION NOTES (CONTD.)**

32. ALL PROPOSED POTABLE WATER MAINS SHALL BE FLUSHED, DISINFECTED, PRESSURE TESTED AND BACTERIOLOGICALLY CLEARED FOR SERVICE WHEN APPROPRIATE IN ACCORDANCE WITH THE LATEST AWWA STANDARDS AND THE FLORIDA DEPARTMENT OF ENVIRONMENTAL PROTECTION REQUIREMENTS. THE CONTRACTOR SHALL NOTIFY THE CITY'S DESIGNATED SITE INSPECTOR WHO SHALL COORDINATE WITH CITY PERSONNEL AT THE WATER TREATMENT PLANT AT LEAST 48 HOURS PRIOR TO BEGINNING FLUSH OF THE MAINS PRIOR TO THE COMMENCEMENT OF PRESSURE TESTING.
33. THE CONTRACTOR SHALL BE REQUIRED TO PIG ALL POTABLE MAINS IN EXCESS OF 8" IN DIAMETER AND PRIMARY DISTRIBUTION MAINS LOCATED ON COLLECTOR AND ARTERIAL ROADWAYS. LAUNCHING AND EXTRACTION POINTS SHALL BE DETERMINED BY THE CONTRACTOR.
34. WITH RESPECT TO TIE-IN CONNECTIONS, THE CITY RESERVES THE RIGHT TO REQUIRE CONNECTIONS TO BE PERFORMED DURING PERIODS OF LOW FLOW (MIDNIGHT TO 6:00 A.M.) IN ORDER TO MINIMIZE SERVICE DISRUPTION TO EXISTING CUSTOMERS.
35. ALL WORK PERFORMED UPON POTABLE WATER FACILITIES OWNED OR PROPOSED TO BE OWNED BY THE CITY SHALL BE CONSTRUCTED BY AN UNDERGROUND UTILITY CONTRACTOR OR GENERAL CONTRACTOR LICENSED IN THE STATE OF FLORIDA AND REGISTERED WITH THE CITY.
36. FOR CONSTRUCTION PURPOSES, THE PLANS SHALL DIMENSION THE PROPOSED LOCATIONS OF ALL WATER MAINS MEASURED FROM THE BACK OF CURB (OR EDGE OF PAVEMENT, IF NO CURB IS USED).
37. POTABLE WATER SYSTEM EXTENSIONS MAY NOT BE USED PRIOR TO FINAL TESTING, CLEARANCE AND ACCEPTANCE BY THE CITY OF EDGEWATER. THIS INCLUDES CONSTRUCTION WATER REQUIRED FOR SEWER LINE CLEANING OR RELATED USES.
38. ALL H.D.P.E. PIPE UTILIZED FOR WATER, FORCE MAIN AND/OR RECLAIMED WATER MAIN EXTENSIONS SHALL BE S.D.R. 11 UNLESS SPECIFICALLY NOTED OTHERWISE. THE HDPE PIPE SHALL BE SIZED TO MATCH THE EXTERNAL DIAMETER OF THE PVC OR DIP PIPE TO WHICH IT IS ATTACHED.
39. LANDSCAPE PLANS SHALL CLEARLY DEPICT THE DESIGN LOCATION OF PLANTINGS RELATIVE TO THE LOCATION OF PUBLIC UTILITIES AND STORMWATER INFRASTRUCTURE IN ORDER TO EVALUATE POTENTIAL CONFLICTS.
40. ALL VALVES 2" AND LARGER SHALL BE STANDARD 2" BOX VALVES (CORP STOPS ARE NOT ACCEPTABLE).
41. WHERE POTABLE WATER AND SANITARY SEWER MAINS CROSS WITH LESS THAN EIGHTEEN (18) INCHES OF VERTICAL CLEARANCE OR WHERE THE SEWER MAIN IS ABOVE THE WATER MAIN, THE SEWER MAIN SHALL BE ENCASED WITH CONCRETE OR ENCLOSED IN A WATER TIGHT CARRIER PIPE, OR UPGRADED TO DUCTILE IRON PIPE OR PRESSURE RATED PVC PIPE (MEETING THE AWWA C-900 OR C905 SPECIFICATION) FOR A MINIMUM LENGTH OF (20) FEET, CENTERED ON THE POINT OF CROSSING. A MINIMUM HORIZONTAL SEPARATION OF (10) TEN FEET (EDGE TO EDGE) BETWEEN POTABLE WATER MAINS AND SEWER MAINS SHALL BE MAINTAINED WHEN AT ALL POSSIBLE. WHEN THE 10-FOOT HORIZONTAL SEPARATION CANNOT BE MAINTAINED THE WATER MAIN SHALL BE INSTALLED IN A SEPARATE TRENCH OR ON AN UNDISTURBED EARTH SHELF AT LEAST 18" ABOVE THE SEWAGE MAIN. ALTERNATIVELY, THE SEWER MAIN SHALL BE ENCASED WITH CONCRETE OR ENCLOSED IN A WATER TIGHT CARRIER PIPE, OR UPGRADED TO DUCTILE IRON PIPE OR PRESSURE RATED PVC PIPE (MEETING THE AWWA C-900 OR C-905 SPECIFICATION) AND PRESSURE TESTED.



**STANDARD CONSTRUCTION DETAIL
POTABLE WATER DESIGN AND
CONSTRUCTION NOTES**

FILE NAME:

EW_W24.DWG

DETAIL REF:

W-24

**TECHNICAL SPECIFICATIONS FOR MECHANICAL JOINT
DUCTILE IRON PIPE FITTINGS**

ALL MECHANICAL JOINT DUCTILE IRON PIPE FITTINGS SHALL BE IN ACCORDANCE WITH ACCEPTABLE STANDARDS AND COMPLY WITH THE FOLLOWING SPECIFICATIONS:

MATERIAL:

A.S.T.M. A536 MINIMUM GRADE 70-50-5 IN ACCORDANCE WITH A.W.W.A. C153 (A.N.S.I. A21.53)

PRESSURE:

CLASS 350 IN ACCORDANCE WITH A.W.W.A. C153 (A.N.S.I. A21.53) 350 PSI WATER WORKING PRESSURE.

TESTING:

IN ACCORDANCE WITH A.W.W.A. C153 (ANSI A21.53). THREE TIMES WATER WORKING PRESSURE (350 PSI). BODY CAPABLE OF WITHSTANDING HYDROSTATIC TEST OF 1050 PSI.

FLOW:

I.D. EQUAL TO I.D. OF CLASS 50/51 DUCTILE IRON PIPE, THUS ALLOWING THE FULL FLOW FEATURE.

LAYING LENGTH:

SHORT BODY (COMPACT)

CEMENT LINING:

IN ACCORDANCE WITH A.W.W.A. C104 (A.N.S.I. A21.4)

MECHANICAL JOINTS:

IN ACCORDANCE WITH A.N.S.I./A.W.W.A. C111/A21.11

GASKETS:

SBR IN ACCORDANCE WITH A.W.W.A. C111 A.N.S.I. A21.11

**TEE HEAD
BOLTS:**

COR-TEN IN ACCORDANCE WITH A.W.W.A. C111 (A.N.S.I. A21.11)

ACCEPTABLE MANUFACTURERS:

TYLER, CLOW, GRIFFIN, U.S. PIPE, UNION FOUNDRY, AMERICAN CAST IRON
OR APPROVED EQUAL



**STANDARD CONSTRUCTION DETAIL
TECHNICAL SPECIFICATIONS FOR
MECHANICAL JOINT
DUCTILE IRON PIPE FITTINGS**

FILE NAME:

EW_W25.DWG

DETAIL REF:

W-25

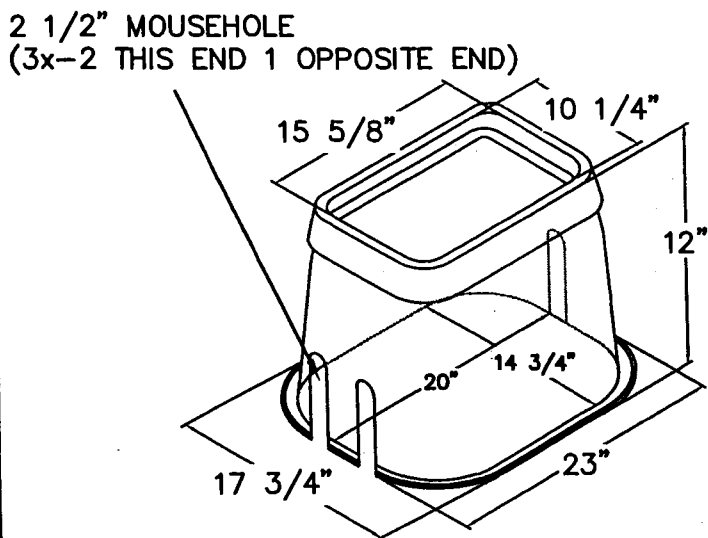
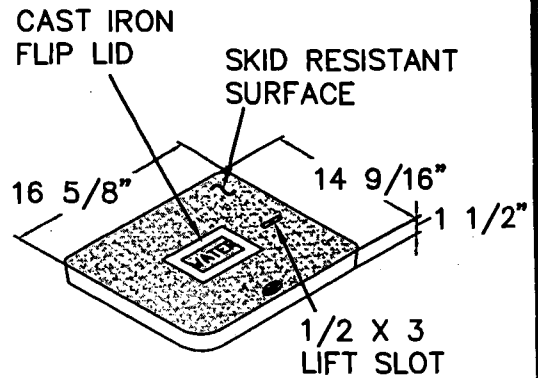
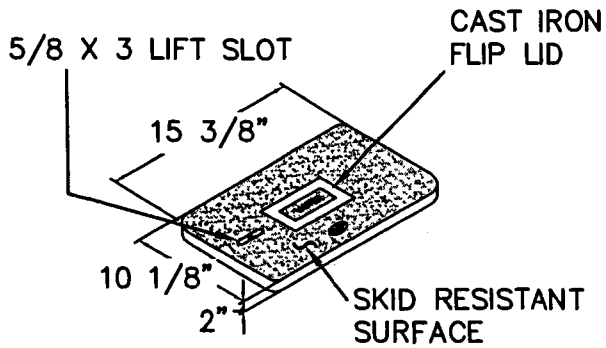

SINGLE SERVICE USE
WA00-1015-12TR-0080

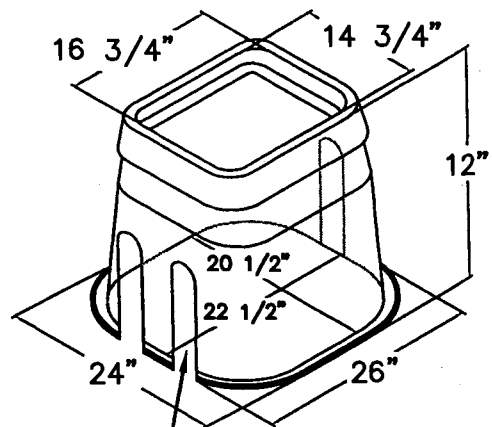

2 1/2" MOUSEHOLE
(3x-2 THIS END 1 OPPOSITE END)

DOUBLE SERVICE USE
WA00-1517-12TR2-0047



STANDARD CONSTRUCTION DETAIL
VALVE BOX
SINGLE AND DOUBLE SERVICE

FILE NAME:

EW_W26.DWG

DETAIL REF:

W-26