

# INDEX

## STORM DRAINAGE DETAILS

ST-1	STORM INLET APRON
ST-2	CONCRETE SPILLWAY
ST-3	PAVEMENT TRENCH RESTORATION
ST-4	STORM DRAINAGE DESIGN AND CONSTRUCTION NOTES
ST-5	STORM DRAINAGE DESIGN AND CONSTRUCTION NOTES
ST-6	STORM DRAINAGE DESIGN AND CONSTRUCTION NOTES
ST-7	CANAL AND WATERWAY DESIGN AND CONSTRUCTION NOTES
ST-8	BRIDGE DESIGN AND CONSTRUCTION NOTES
ST-9	DRY RETENTION POND PLACEMENT BY R/W AND EASEMENT LINES
ST-10	WET RETENTION POND PLACEMENT BY R/W AND EASEMENT LINES
ST-11	TYPE "C" STORM INLET
ST-12	TYPE "E" STORM INLET
ST-13	EXFILTRATION TRENCH



STANDARD CONSTRUCTION DETAIL  
INDEX  
STORM DRAINAGE DETAILS

FILE NAME:  
STRMINDX.DWG  
DETAIL REF:  
INDEX

1/2" EXPANSION  
JOINT TYP.

1' STRIP OF  
SOD TYP.

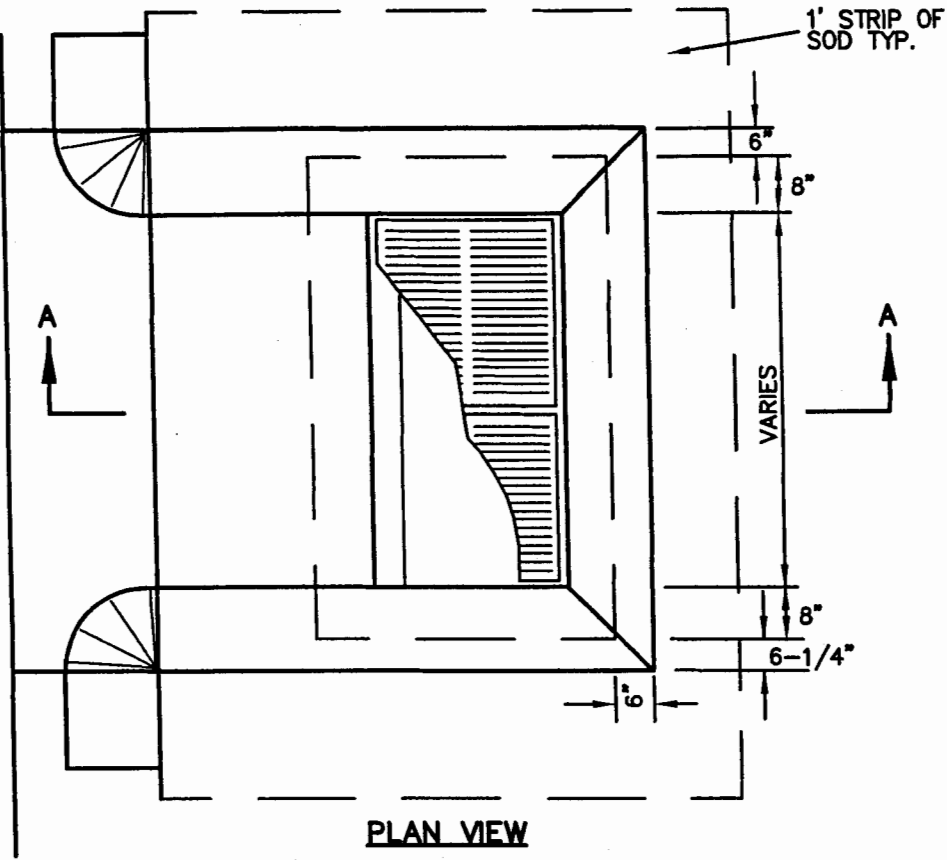

**PLAN VIEW**

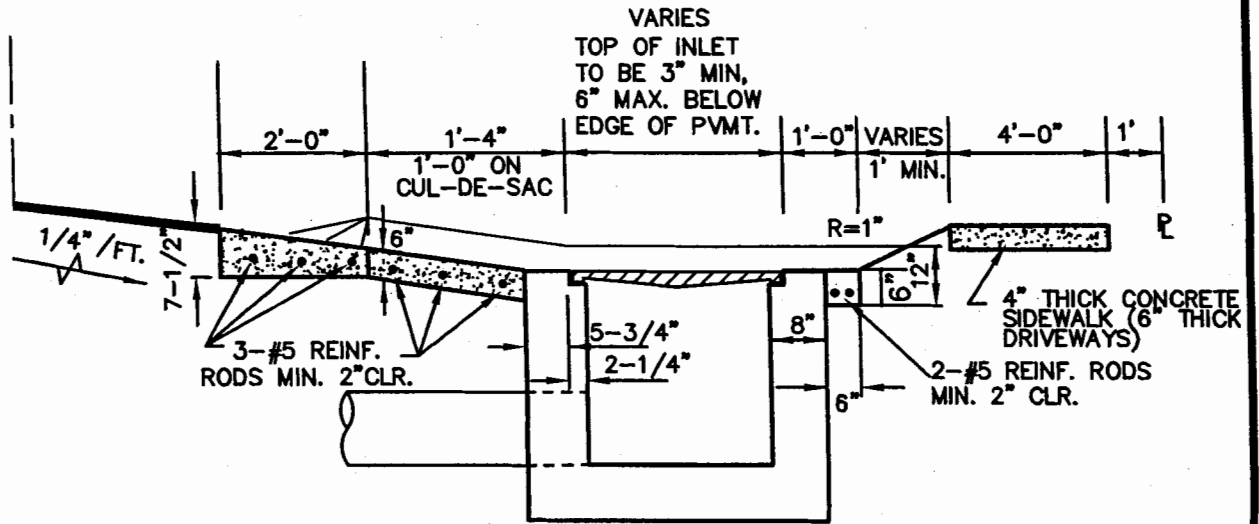

**SECTION A-A**



**STANDARD CONSTRUCTION DETAIL  
STORM INLET APRON**

FILE NAME:

EW\_ST1.DWG

DETAIL REF:

**ST-1**

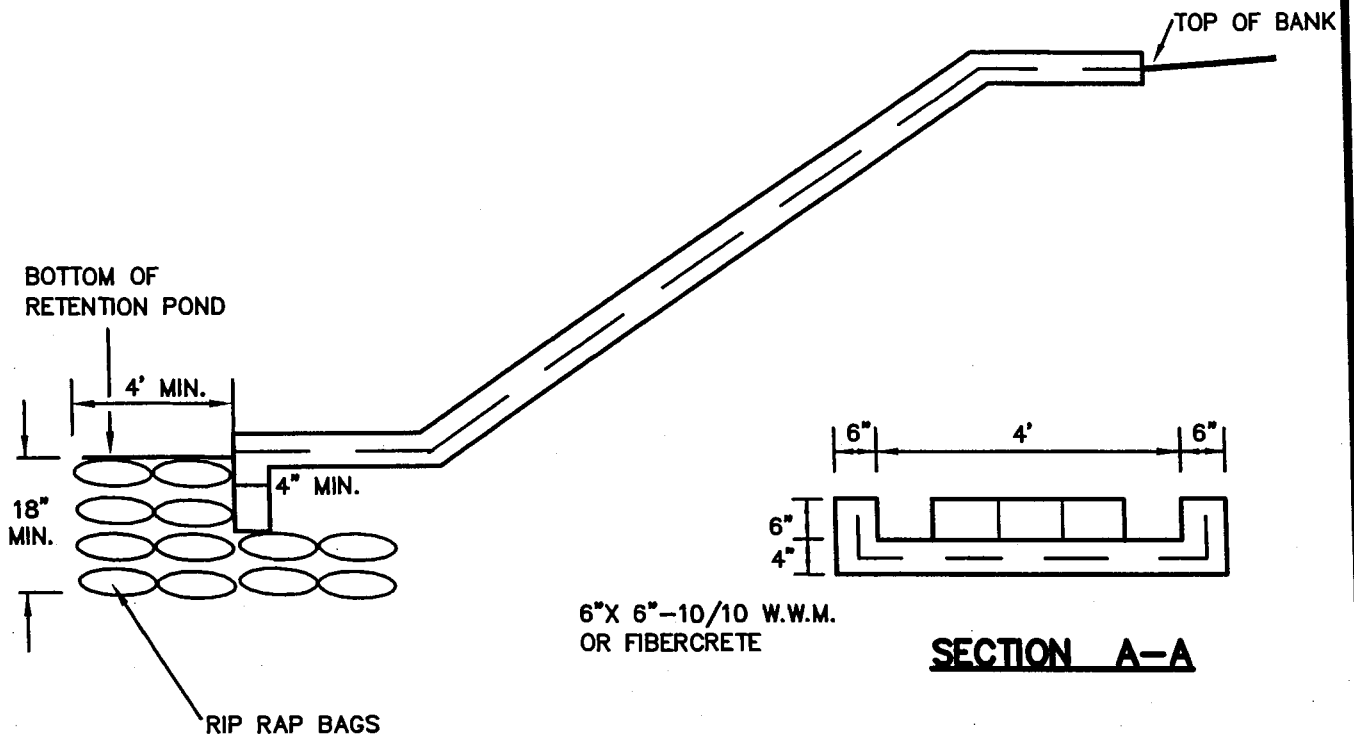
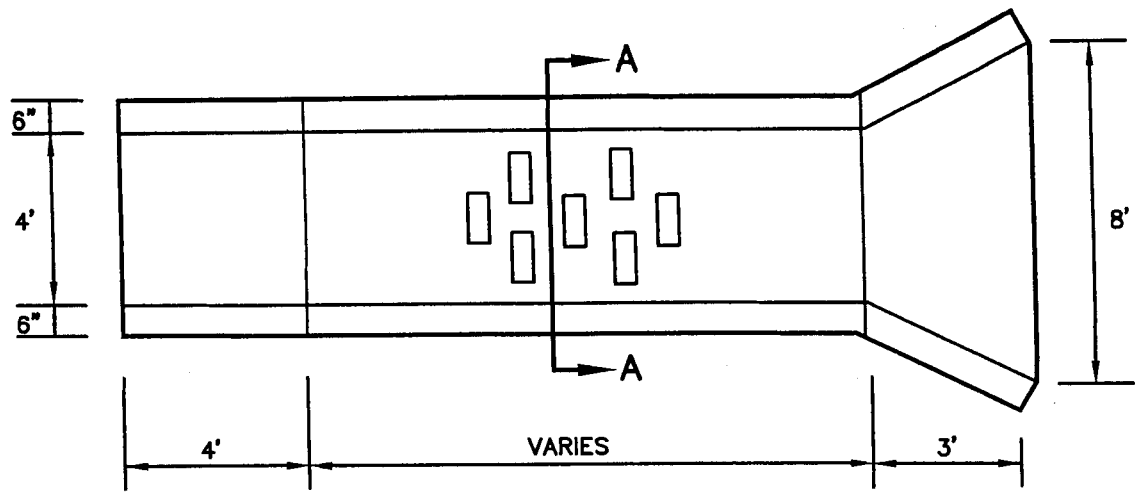

**NOTES:**

1. CONCRETE SPILLWAY TO BE 28 DAY, 3000 P.S.I., 4" THICK.
2. PLACE SOD AT LEAST 5' AROUND ALL STRUCTURE EDGES ABOVE STANDING WATER.
3. PLACE RIP RAP BAGS UNDER BOTTOM OF END OF SPILLWAY 4' AND 18" MINIMUM DEPTH.



**STANDARD CONSTRUCTION DETAIL  
CONCRETE SPILLWAY**

FILE NAME:	EW_ST2.DWG
DETAIL REF:	ST-2

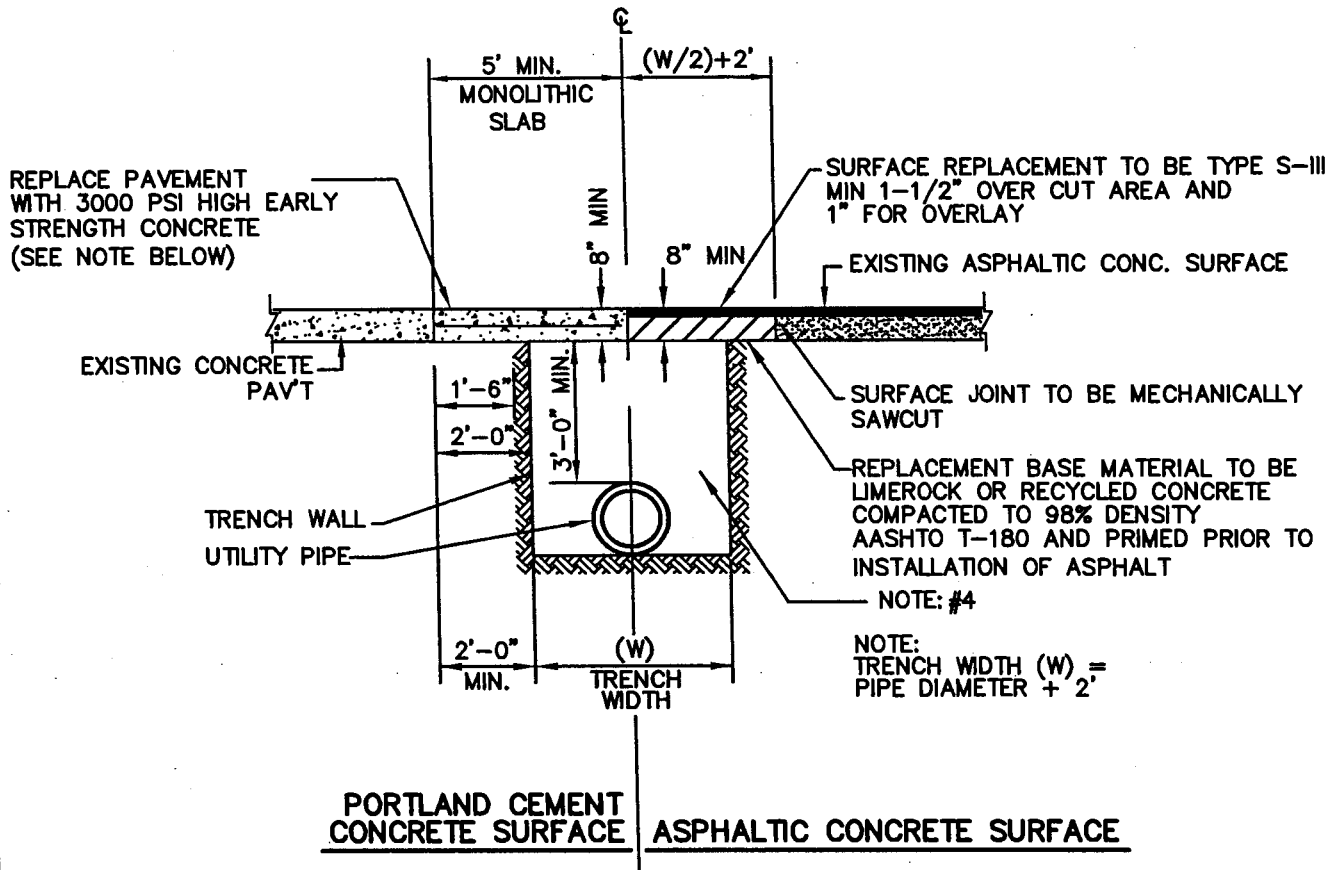

**NOTES:**

1. PAVING REPLACEMENT SHALL INCLUDE RAISING ALL MANHOLE FRAMES AND LIDS AND VALVE BOXES AND LIDS (AND SIMILAR APPURTENANCES) TO FINAL ELEVATION PRIOR TO RESURFACING
2. SUBBASE TO BE COMPACTED TO 98% MAXIMUM DENSITY AASHTO T-180
3. IN AREAS WHERE CONCRETE PAVEMENT IS TO BE UTILIZED, 3000 PSI - 28 DAY STRENGTH CONCRETE PAVEMENT MAY BE PERMITTED PROVIDED THAT THE SUBJECT AREA WILL REMAIN FREE OF VEHICULAR TRAFFIC FOR A MINIMUM OF 3 DAYS.
4. 350 PSI. FLOWABLE FILL SHALL BE USED UPON DIRECTION BY CITY ENGINEER.



**STANDARD CONSTRUCTION DETAIL  
PAVEMENT TRENCH RESTORATION**

FILE NAME:

EW\_ST3.DWG

DETAIL REF:

**ST-3**

## STORM DRAINAGE DESIGN AND CONSTRUCTION NOTES

ALL MATERIALS AND INSTALLATION METHODS USED FOR LAND DEVELOPMENT CODE REQUIRED IMPROVEMENTS FOR SUBDIVISIONS AND SITE PLANS SHALL BE IN CONFORMANCE WITH THE CITY, FDOT STANDARD SPECIFICATIONS FOR ROAD AND BRIDGE CONSTRUCTION (LATEST EDITION), AND THE FDOT ROADWAY AND TRAFFIC DESIGN STANDARDS (LATEST EDITION).

1. ALL STORM SEWERS AND CULVERTS LOCATED IN ROADWAY RIGHTS-OF-WAY AND ROADWAY EASEMENTS SHALL BE A MINIMUM OF CLASS III REINFORCED CONCRETE PIPE. PRIVATE SITES AND AREAS OUTSIDE OF ROADWAY EASEMENTS AND R.O.W., PIPE MAY BE MADE OF ALTERNATE MATERIALS INCLUDING:
  - A. SMOOTH INNER WALL HIGH DENSITY POLYETHYLENE (HDPE) IN ACCORDANCE WITH AASHTO M-294, AASHTO MP7, ASTM D3350 AND ASTM D2412 FOR SIZES UP TO 42" IN DIAMETER OR
  - B. PVC IN ACCORDANCE WITH THE PROVISION NOTED IN THE "SEWER DETAILS" OF THESE SPECIFICATIONS.
2. ALL STORM SEWER PIPE JOINTS LOCATED IN ROADWAY RIGHTS-OF-WAY AND ROADWAY EASEMENTS SHALL BE ENTIRELY WRAPPED WITH FILTER FABRIC WITH A MINIMUM WIDTH OF 24" AND A MINIMUM OF 24" OVERLAP SECURED WITH PLASTIC OR STAINLESS BANDS. GASKETS ARE NOT PERMITTED AS AN EQUIVALENT SUBSTITUTE FOR MEETING THIS REQUIREMENT. THIS PRACTICE IS ENCOURAGED ON PRIVATE SITES. ADDITIONALLY, ALL JOINTS SHALL BE RUBBER GASKETED FOR BOTH ROUND AND ELLIPTICAL PIPE.
3. DEPTH OF COVER MEASURED TO THE TOP OF PIPE (NOT INCLUDING THE BELL JOINT) SHALL BE A MINIMUM OF 1 FOOT. DEVIATION FROM THIS REQUIREMENT MAY BE ALLOWED BY INCREASING THE PIPE'S STRUCTURAL CAPACITY. THIS DEVIATION MUST BE SPECIFIED ON THE PLANS APPROVED FOR CONSTRUCTION AND SUBSEQUENTLY REFLECTED ON THE SHOP DRAWINGS AND AS-BUILT PLANS.
4. ALL STORM DRAINAGE PIPES LOCATED IN ROADWAY RIGHTS-OF-WAY AND ROADWAY EASEMENTS SHALL BE A MINIMUM OF TWELVE INCH (12") DIAMETER OR EQUIVALENT AND BE DESIGNED FOR A MINIMUM OF A TWENTY-FIVE (25) YEAR STORM OF TWENTY-FOUR (24) HOUR DURATION. STORM DRAINAGE PIPES SMALLER THAN 12" ARE PERMITTED ON PRIVATE SITE PLANS PROVIDING THAT MAINTENANCE SHALL BE PERFORMED BY THE OWNER.
5. STORM INLETS, MANHOLES, AND CATCH BASINS SHALL BE EITHER POURED IN PLACE OR PRECAST REINFORCED CONCRETE. STRUCTURES SHALL BE REQUIRED AT EACH CHANGE OF PIPE SIZE OR CHANGE IN PIPE DIRECTION. ALL STRUCTURES SHALL BE IN COMPLIANCE WITH ASTM C-478 AND SHALL HAVE 8" THICK WALLS. 6" THICK WALLS MAY BE PERMITTED PROVIDING THAT THE PLANS SPECIFY INCREASED REINFORCEMENT IN ACCORDANCE WITH FDOT STANDARD INDEX NO. 201 IN ADDITION, THIS REQUIREMENT MUST BE REFLECTED ON BOTH THE SHOP DRAWING AND AS-BUILT PLANS. NOTE: INLET APRONS MAY REQUIRE EXPANSION JOINTS AROUND THE STRUCTURE AS DICTATED BY THE CITY.
6. STORM INLETS SHALL BE SPACED IN SUCH A MANNER AS TO ACCEPT ONE HUNDRED (100) PERCENT OF THE DESIGN STORM RUNOFF WITHOUT IMPEDING THE FLOW OF TRAFFIC. FOR ROADWAY SECTIONS WITH DESIGN SPEEDS OF 45 MPH AND LESS AND WITHOUT FULL WIDTH SHOULDERS, SPREAD RESULTING FROM A RAINFALL INTENSITY OF FOUR INCHES (4 ") PER HOUR SHALL NOT EXCEED ONE-HALF OF THE TRAVEL LANE ADJACENT TO THE GUTTER. FOR SITE PLANS, INLET SPACING SHALL BE DESIGNED TO ACCEPT ONE HUNDRED (100) PERCENT OF THE RUNOFF FROM A RAINFALL INTENSITY OF FOUR INCHES (4 ") PER HOUR WITHOUT RESULTING IN PONDING OF WATER AROUND THE INLET.
7. LAKE DEPTHS SHALL BE EIGHT FEET (8') MINIMUM TO TWELVE FEET (12') MAXIMUM, MEASURED FROM HIGH WATER MARK.



### STANDARD CONSTRUCTION DETAIL STORM DRAINAGE DESIGN AND CONSTRUCTION NOTES

FILE NAME:

EW\_ST4.DWG

DETAIL REF:

ST-4

**STORM DRAINAGE DESIGN AND CONSTRUCTION NOTES**  
**(CONTD.)**

8. FOR CONNECTIONS BETWEEN INLETS WITH PIPING 15" IN DIAMETER AND LARGER, THE MAXIMUM DISTANCES BETWEEN INLETS AND / OR CLEAN-OUT JUNCTION BOXES SHALL BE 300 FEET. CULVERTS SHALL BE SLOPED TO MAINTAIN A MINIMUM SELF-CLEANING VELOCITY OF 3 FEET PER SECOND USING A MANNING'S 'n' OF 0.012. SPACING FOR CLEAN-OUTS AND INLETS FOR SMALLER PIPING SHALL BE REDUCED AND EVALUATED ON A CASE BY CASE BASIS.
9. THE MAXIMUM PERMISSIBLE SLOPE OF ANY NEW SITE GRADING IS 3:1 (HORIZONTAL:VERTICAL). THIS LIMIT SHALL BE APPLIED TO ALL AREAS EXCEPT STORMWATER CONVEYANCE AND TREATMENT SYSTEMS WHICH HAVE A MAXIMUM SLOPE OF 4:1 (EXCEPT BELOW THE WATER TABLE WHERE SHARPER SLOPES ARE PERMISSIBLE.)
10. ALL SWALES AND DITCHES SHALL HAVE A MAXIMUM PERMITTED SIDE SLOPE NOT GREATER THAN 4 TO 1 AT A MINIMUM. THE MAXIMUM PERMITTED BACKSLOPE, SHALL BE 3:1, PROVIDED THAT A 2' WIDE BERM IS INSTALLED. DESIGN CENTERLINE AND TOP-OF-BANK ELEVATIONS SHALL BE NOTED AT INTERVALS OF 100'.
11. SWALES THAT ARE NORMALLY DRY AND INTENDED FOR CONVEYANCE OF STORMWATER RUNOFF AND ARE NOT INTENDED FOR RETENTION SHALL HAVE A MINIMUM DRAINAGE MAINTENANCE EASEMENT WIDTH MEASURING 15 FEET. SWALED AREAS INTENDED FOR RETENTION SHALL PROVIDE APPROPRIATE EASEMENT AREAS FOR ACCESS AND MAINTENANCE MEASURED UPLAND FROM THE TOP OF BANK. AT A MINIMUM, THE SAID EASEMENT SHALL MEASURE 10' FEET IN WIDTH FROM THE TOP OF THE SWALE.
12. PIPED STORMWATER SYSTEMS SHALL HAVE A MINIMUM DRAINAGE MAINTENANCE EASEMENT WIDTH OF 20 FEET, AND MAY BE INCREASED DEPENDING UPON THE SIZE AND DEPTH OF PIPE.
13. NORMAL ROADSIDE SWALES ARE PERMITTED TO BE CONSTRUCTED TO A MAXIMUM DEPTH OF 18" BELOW THE OUTSIDE EDGE OF PAVEMENT OR CONCRETE CURB.
14. CONCRETE EROSION CONTROL MUST BE PROVIDED WHERE SWALES OR CULVERTS INTERCEPT DRAINAGE DITCHES.
15. WHEN A LAKE IS INCORPORATED WITHIN A SUBDIVISION AND IS ABUTTED BY LOTS, SUCH ABUTTING LOT LINES SHALL BE EXTENDED INTO THE LAKE PROPORTIONATELY ENCOMPASSING ALL OF THE LAKE AREA.
16. LAKE INFLOW AND OUTLET STRUCTURES SHALL GENERALLY BE CONSTRUCTED WITH REINFORCED CONCRETE AND SHALL BE SUBJECT TO THE APPROVAL OF THE CITY. SKIMMERS FOR WET PONDS SHALL BE CONSTRUCTED SUCH THAT THE BOTTOM EXTENDS 6" BELOW THE NORMAL WATER LEVEL AND 6" ABOVE THE OVERFLOW. FOR DRY PONDS, THE SKIMMER BOTTOM SHALL BE SET 6" BELOW THE LOWEST OVERFLOW ELEVATION AND 6" ABOVE THE HIGHEST POINT OF OVERFLOW. ALL SKIMMERS SHALL BE CONSTRUCTED OF MINIMUM 1/4" THICK ALUMINUM OR FIBERGLASS ADEQUATELY SUPPORTED TO PREVENT DEFLECTION.



**STANDARD CONSTRUCTION DETAIL**  
**STORM DRAINAGE DESIGN**  
**AND CONSTRUCTION NOTES**

**FILE NAME:**

EW\_ST5.DWG

**DETAIL REF:**

**ST-5**

**STORM DRAINAGE DESIGN AND CONSTRUCTION NOTES**  
**(CONTD.)**

17. EROSION AND SEDIMENT CONTROL PLANS AS APPROVED BY THE FLORIDA DEPARTMENT OF ENVIRONMENTAL PROTECTION SHALL BE EMPLOYED AT ALL TIMES. AT A MINIMUM, BEST MANAGEMENT PRACTICES (BMP's) SHALL BE UTILIZED.
18. THE CITY MAY REQUEST THAT THE DEVELOPER SUBMIT A REPORT BY A QUALIFIED HYDROLOGIST ON THE IMPACT THE LAKE WILL HAVE ON NEIGHBORING WATER TABLE ELEVATIONS BOTH DURING CONSTRUCTION AND AFTER LAKE COMPLETION. THE CITY MAY REQUIRE GROUNDWATER MONITORING DURING THE LAKE EXCAVATION.
19. ADEQUATE MAINTENANCE EASEMENTS OR RIGHTS-OF-WAY AS APPROVED BY THE CITY SHALL BE PROVIDED AROUND THE ENTIRE PERIMETER OF ALL LAKES AND ASSOCIATED OUTFALLS DISCHARGING INTO AND OUT OF LAKES. APPLICABLE CROSS SECTIONS SHALL BE INCLUDED ON ALL FINAL DEVELOPMENT PLANS.
20. DEVELOPMENT PLANS FOR ALL STORMWATER MANAGEMENT SYSTEMS SHALL CONTAIN POP-OFF DATA (OVERFLOW), BOTTOM ELEVATION, NORMAL WATER LEVELS, MEAN ANNUAL SEASONAL HIGH WATER TABLE ELEVATION, TREATMENT VOLUME AND CORRESPONDING ELEVATION, 100 YEAR HIGH WATER LEVELS, AND THE DESIGN TAILWATER ELEVATION (IF APPLICABLE).
21. IN GENERAL, ALL RETENTION / DETENTION SITES MUST BE CONSTRUCTED ON ALL PROJECTS PRIOR TO ANY ROAD, PARKING LOT, OR BUILDING CONSTRUCTION COMMENCING OR AS CURRENT PERMIT CONDITIONS DICTATE. SEWER AND WATER MAINS MAY BE INSTALLED PRIOR TO RETENTION/DETENTION SITE CONSTRUCTION IF DEWATERING IS NOT REQUIRED.
22. THE CONTRACTOR SHALL BE RESPONSIBLE TO OBTAIN ANY AND ALL DEWATERING PERMITS THAT MAY BE REQUIRED.
23. WHEN CULVERTS ARE INSTALLED TO MAINTAIN THE FLOW OF EXISTING DRAINAGE WAYS WHERE NEWLY PROPOSED ROADS WOULD OTHERWISE SEVER THE DRAINAGE WAY, THEN CULVERTS CROSSING RIGHTS-OF-WAY SHALL EXTEND FROM RIGHT-OF-WAY LINE TO RIGHT-OF-WAY LINE UNDER THE ROADWAY. CULVERTS SHALL BE DESIGNED TO ACCOMODATE THE FLOW FROM THE 100 YEAR - 24 HOUR STORM EVENT WITHOUT FLOODING ADJACENT PROPERTY OR SURCHARGING THE SAID ROADWAY.
24. IT SHALL BE THE RESPONSIBILITY OF THE CONTRACTOR TO REVIEW AND MAINTAIN A COPY OF THE SJRWMD PERMIT AND/ OR NPDES CONSTRUCTION PERMIT AT THE CONSTRUCTION SITE, AND ABIDE BY ALL CONDITIONS OF THE PERMIT.
25. LANDSCAPE PLANS SHALL CLEARLY DEPICT THE DESIGN LOCATION OF PLANTINGS RELATIVE TO THE LOCATION OF PUBLIC UTILITIES AND STORMWATER INFRASTRUCTURE IN ORDER TO EVALUATE POTENTIAL CONFLICTS.



**STANDARD CONSTRUCTION DETAIL**  
**STORM DRAINAGE DESIGN**  
**AND CONSTRUCTION NOTES**

**FILE NAME:**

**EW\_ST6.DWG**

**DETAIL REF:**

**ST-6**

## CANAL AND WATERWAY DESIGN AND CONSTRUCTION NOTES

1. CANALS AND WATERWAYS SHALL BE AVOIDED EXCEPT WHEN APPROVED AND DEEMED BY THE CITY TO BE UNAVOIDABLE OR NECESSARY, WHEREIN LITERAL ENFORCEMENT OF THIS CHAPTER WOULD DEPRIVE THE DEVELOPER OF THE REASONABLE USE OF HIS LAND.
2. IN THE EVENT OF SUCH APPROVAL, THE CANALS OR WATERWAYS SHALL HAVE A MINIMUM OF TWENTY FEET (20') ADDITIONAL WIDTH ON EACH BANK MEASURED FROM THE TOP OF BANK AND LOCATED ALONG THE ENTIRE LENGTH OF THE CANAL FOR MAINTENANCE.
3. SUCH CANALS SHALL BE A MAXIMUM OF FORTY FEET (40') IN WIDTH PLUS REQUIRED MAINTENANCE AREAS.
4. CANALS SHALL HAVE A MINIMUM BOTTOM WIDTH OF THREE FEET (3') AND MAXIMUM PERMISSIBLE SIDE SLOPES OF 4:1 (HORIZONTAL: VERTICAL). SHARPER SLOPES MAY BE CONSIDERED BELOW THE NORMAL WATER LEVEL PROVIDING THAT ADDITIONAL BANK STABILIZATION MEASURES ARE INSTALLED BASED UPON THE RECOMMENDATIONS OF A CERTIFIED GEOTECHNICAL ENGINEER. CANAL BANKS SHALL BE SODDED.
5. WATERWAYS AFFECTED BY TIDAL ACTION SHALL HAVE A MINIMUM DEPTH OF NINE FEET (9') BELOW SEA LEVEL REFERENCING THE NATIONAL GEODETIC VERTICAL DATUM (N.G.V.D.). THESE WATERWAYS SHALL BE SEPARATED FROM FRESH WATER BY SALINITY DAMS WITH SPILLWAY ELEVATIONS AS APPROVED BY THE CITY.
6. TWENTY FEET (20') WIDE DRAINAGE/MAINTENANCE EASEMENTS SHALL BE REQUIRED IN ORDER TO PROVIDE FOR THE NORMAL MAINTENANCE OF THESE WATER BODIES. THESE EASEMENTS SHALL BE ESTABLISHED BY THE CITY BASED ON EXISTING AND FUTURE CONDITIONS AS WELL AS THE TYPES OF MAINTENANCE EQUIPMENT AVAILABLE.



### STANDARD CONSTRUCTION DETAIL CANAL AND WATERWAY DESIGN AND CONSTRUCTION NOTES

FILE NAME:

EW\_ST7.DWG

DETAIL REF:

ST-7

## BRIDGE DESIGN AND CONSTRUCTION NOTES

1. BRIDGES SHALL BE CONSTRUCTED WITH HEADER CURB ON BOTH SIDES RUNNING ITS COMPLETE LENGTH.
2. STANDARD 4'-WIDE SIDEWALKS SHALL BE PROVIDED ON BOTH SIDES AS FAR AWAY AS POSSIBLE FROM THE ROADWAY, BUT AT NO TIME CLOSER THAN TWO (2) FEET FROM THE EDGE OF THE FUTURE ROADWAY.
3. APPROACH GUARDRAILS OR FENCES SHALL BE PROVIDED WHERE REQUIRED FOR SAFETY BY THE CITY.
4. BRIDGE GEOMETRY, BRIDGE DESIGN, AND LOADING SHALL CONFORM TO THE DESIGN CRITERIA OF THE LATEST EDITION OF THE AMERICAN ASSOCIATION OF STATE HIGHWAY AND TRANSPORTATION OFFICIALS STANDARD SPECIFICATIONS FOR HIGHWAY BRIDGES.
5. PRIOR TO ACTUAL DESIGN OF THE BRIDGE, THE APPLICANT SHALL SUBMIT DESIGN LOAD CRITERIA TO THE CITY FOR APPROVAL.



### STANDARD CONSTRUCTION DETAIL BRIDGE DESIGN AND CONSTRUCTION NOTES

FILE NAME:

EW\_ST8.DWG

DETAIL REF:

ST-8

15' FROM ADJACENT PROPERTY LINE,  
15' FROM EASEMENT LINE AND  
5' FROM RIGHT-OF-WAY LINE

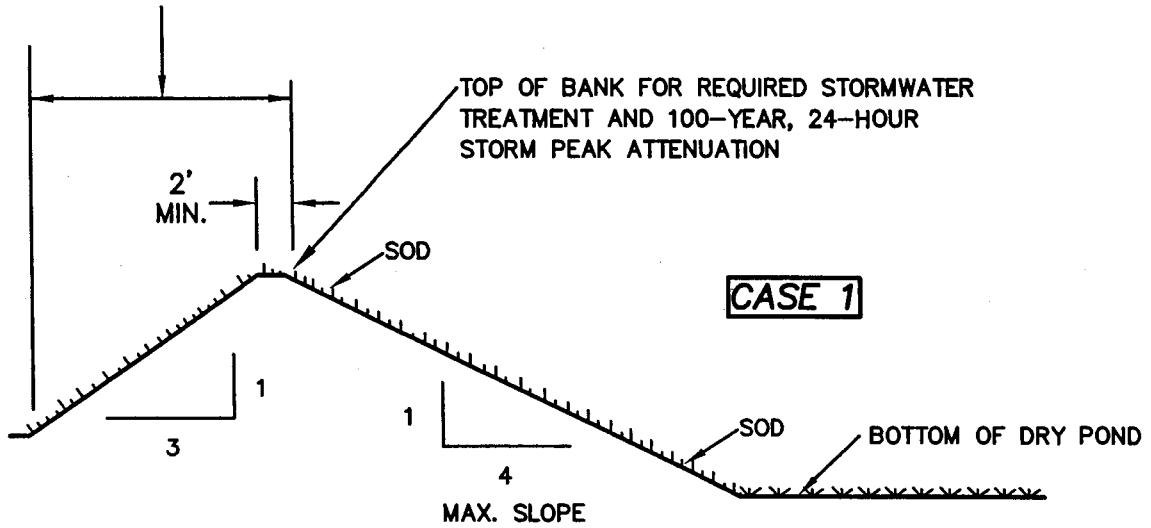

15' FROM ADJACENT PROPERTY LINE  
15' FROM EASEMENT LINE AND  
5' FROM RIGHT-OF-WAY LINE

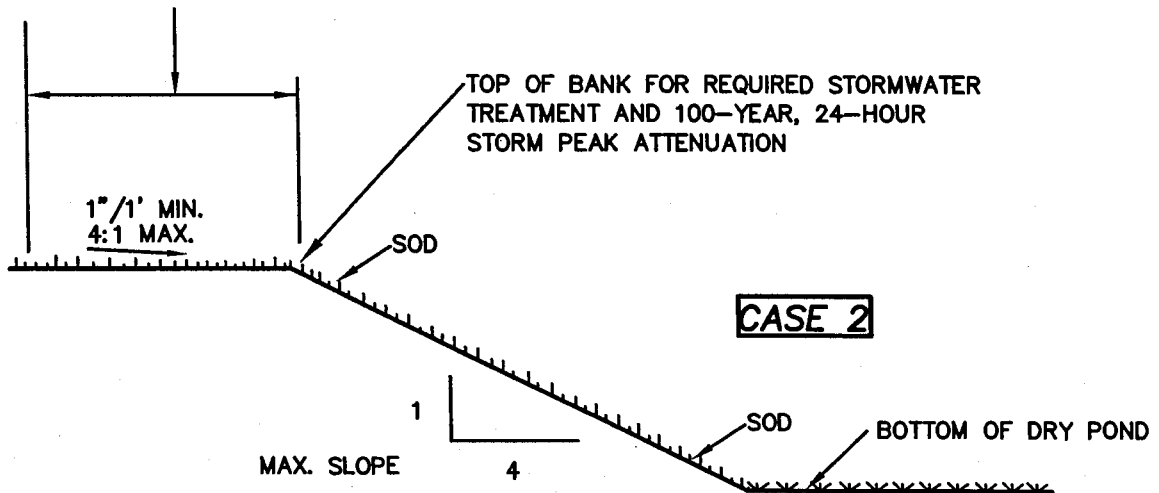

**NOTES:**

1. SOD IS TO BE PLACED TO BOTTOM OF DRY POND.
2. BOTTOM OF DRY POND TO BE SEEDED AND MULCHED (EXCEPT WHERE "A"-TYPE SOILS ARE PRESENT WHICH REQUIRES SODDING OF ENTIRE BOTTOM OF POND).
3. CASE 1 BERM SHALL REQUIRE THE INSTALLATION OF LIMITING SOILS OR OTHER MATERIALS TO REDUCE LATERAL TRANSMISSIVITY.



**STANDARD CONSTRUCTION DETAIL  
DRY RETENTION POND  
PLACEMENT BY R/W AND EASEMENT LINES**

FILE NAME:

EW\_ST9.DWG

DETAIL REF:

ST-9

15' FROM ADJACENT PROPERTY LINE,  
15' FROM EASEMENT LINE AND  
5' FROM RIGHT-OF-WAY LINE

**CASE 1**

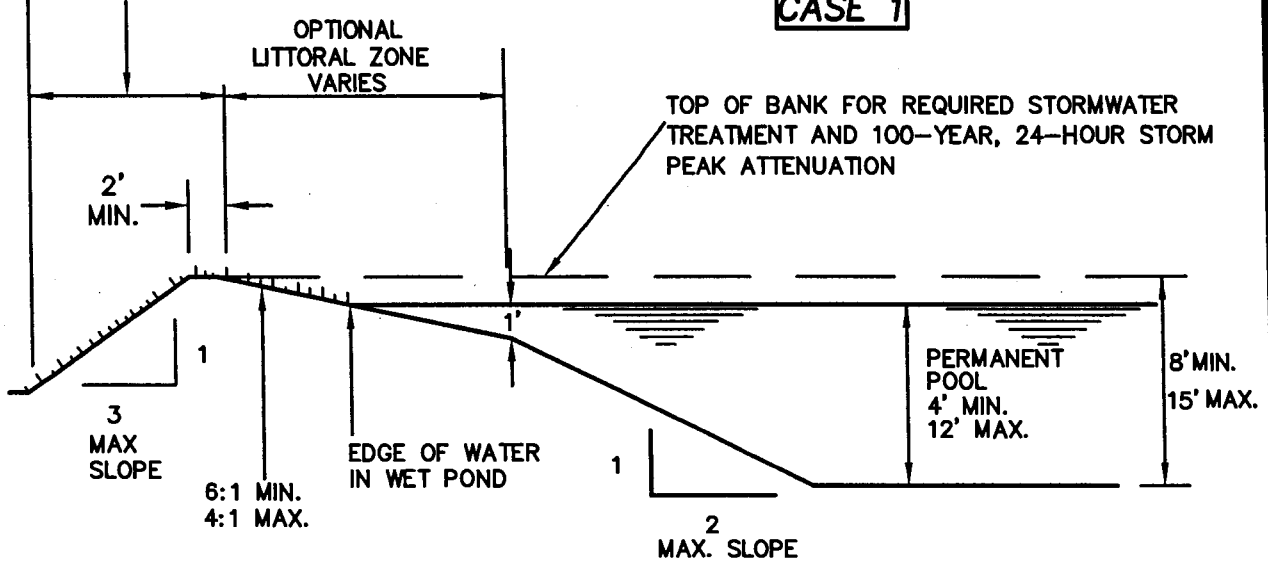

15' FROM ADJACENT PROPERTY LINE,  
15' FROM EASEMENT LINE AND  
5' FROM RIGHT-OF-WAY LINE

**CASE 2**

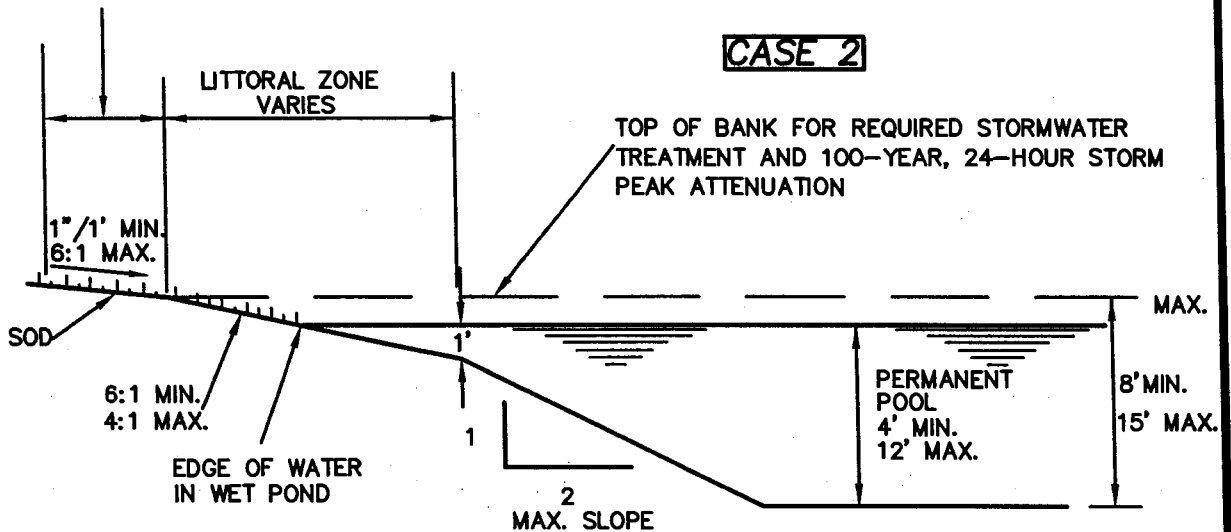

**NOTES:**

1. SOD IS TO BE PLACED TO EDGE OF WATER.
2. A PLANTED LITTORAL ZONE IS NOT PERMISSIBLE FOR SLOPES EXCEEDING 6:1.
3. AS AN OPTION TO A LITTORAL ZONE, THE DESIGNER CAN EITHER:
  - A) PROVIDE AN ADDITIONAL 50% OF THE PERMANENT POOL VOLUME, AS REQUIRED, OR
  - B) PROVIDE PRETREATMENT OF THE STORMWATER PRIOR TO ENTERING THE WET DETENTION POND.
4. CASE 1 BERM SHALL REQUIRE THE INSTALLATION OF LIMITING SOILS OR OTHER MATERIALS TO REDUCE LATERAL TRANSMISSIVITY.



**STANDARD CONSTRUCTION DETAIL  
WET RETENTION POND  
PLACEMENT BY R/W AND EASEMENT LINES**

FILE NAME:

EW\_ST10.DWG

DETAIL REF:

**ST-10**

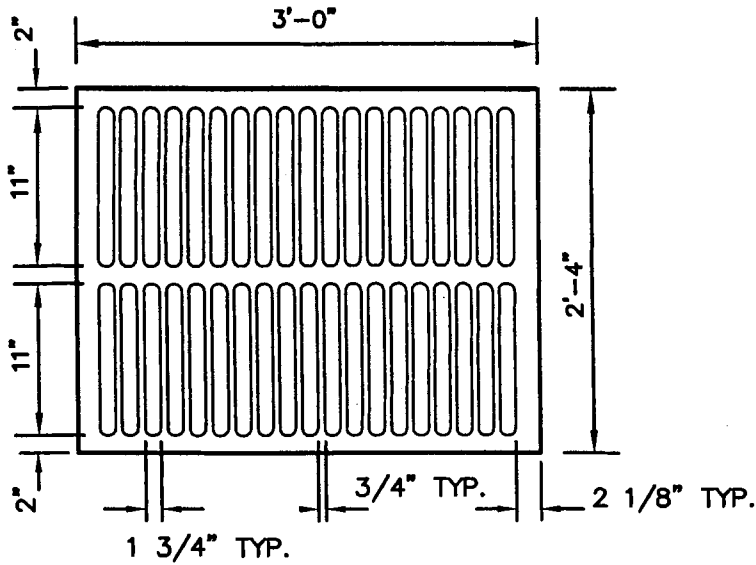

**CAST IRON GRATE**  
INDEX SHT. 232

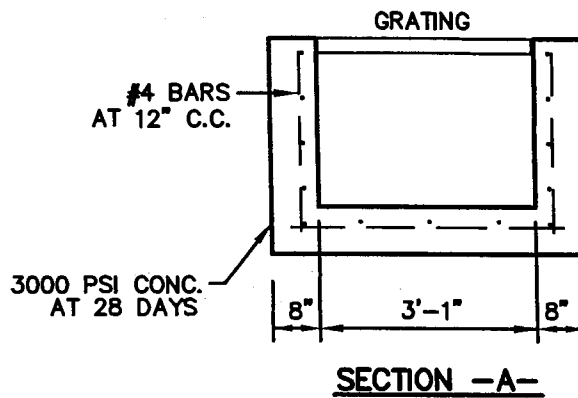
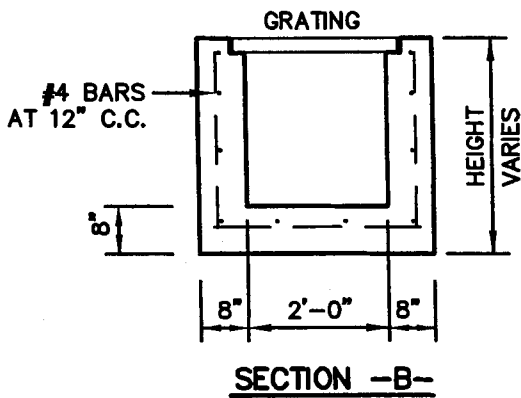
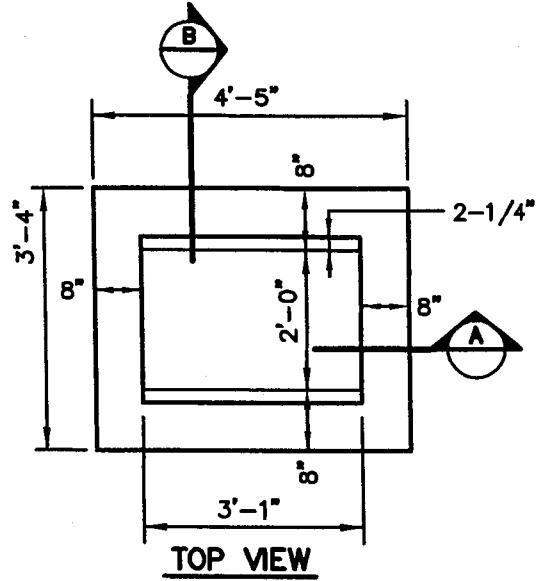
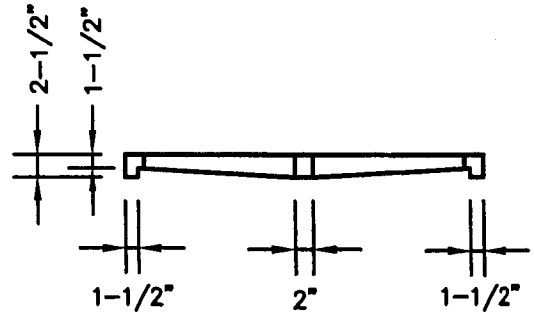

**NOTE:**

\* 6" THICK WALLS MAY BE PERMITTED, PROVIDING THAT THE INCREASED REINFORCEMENT IN ACCORDANCE WITH FDOT STANDARD INDEX NO. 201 IS INSTALLED. THIS MUST BE REFLECTED ON THE DESIGN PLANS, SHOP DRAWINGS, AND AS-BUILTS.

**F.D.O.T. TYPE C INLET**  
INDEX SHT. 232



**STANDARD CONSTRUCTION DETAIL**  
**TYPE "C" STORM INLET**

FILE NAME:

EW\_ST11.DWG

DETAIL REF:

**ST-11**

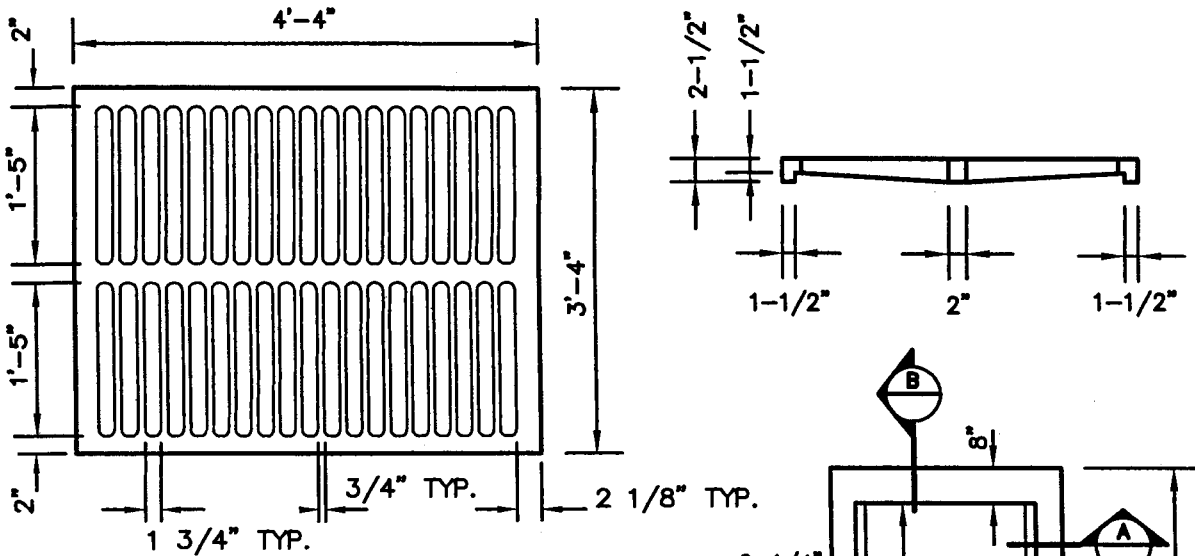

**CAST IRON GRATE**

INDEX SHT. 232

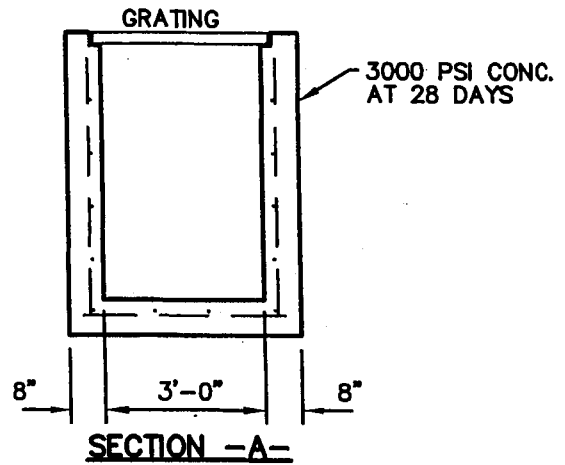
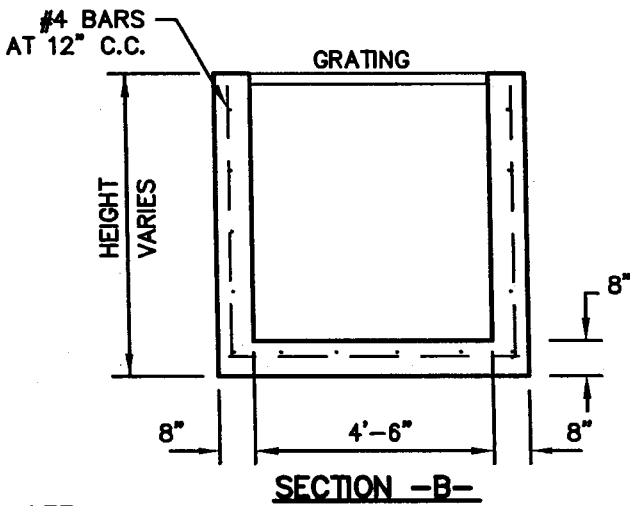
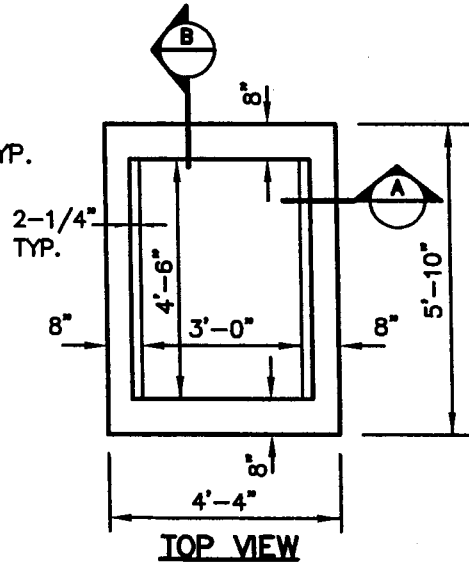

**NOTE:**

\* 6" THICK WALLS MAY BE PERMITTED, PROVIDING THAT THE INCREASED REINFORCEMENT IN ACCORDANCE WITH FDOT STANDARD INDEX NO. 201 IS INSTALLED. THIS MUST BE REFLECTED ON THE DESIGN PLANS, SHOP DRAWINGS, AND AS-BUILTS.

**F.D.O.T. TYPE E INLET**

INDEX SHT. 232



**STANDARD CONSTRUCTION DETAIL  
TYPE "E" STORM INLET**

FILE NAME:

EW\_ST12.DWG

DETAIL REF:

**ST-12**

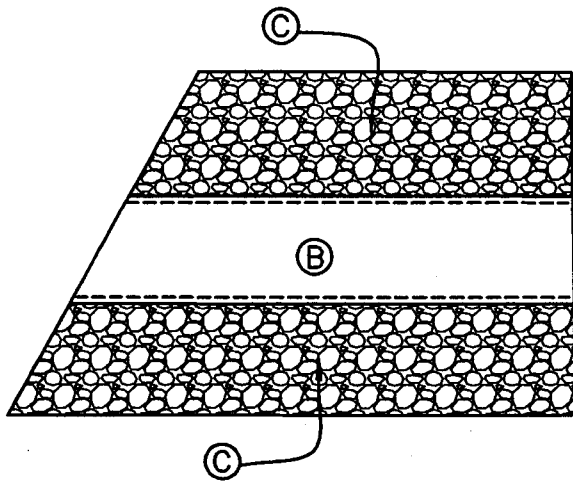

**ELEVATION**  
N.T.S.

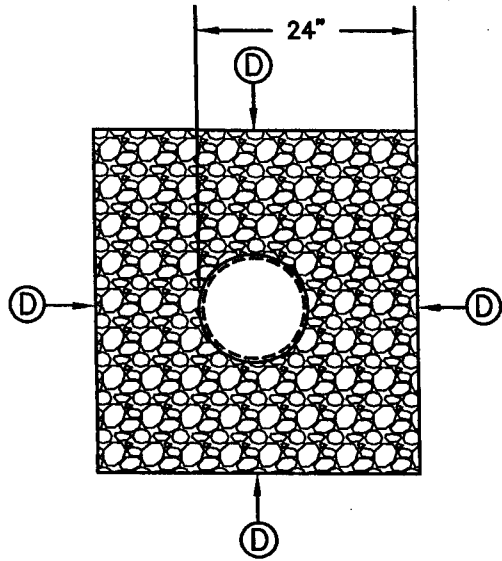

**SECTION**  
N.T.S.

- Ⓑ 12" PERFORATED C.P.P.
- Ⓒ 3/4" WASHED ROCK, #57 AGGREGATE.
- Ⓓ FILTER CLOTH ON ALL SIDES & OVERLAPPING 24" AT TOP.



**STANDARD CONSTRUCTION DETAIL**  
**EXFILTRATION TRENCH**

**FILE NAME:**  
EW\_ST13.DWG

**DETAIL REF:**  
**ST-13**