

# INDEX

## MISCELLANEOUS DETAILS

M-1	PLAN SHEET REQUIREMENTS
M-2	SIDEWALK CONSTRUCTION REQUIREMENTS
M-3	SIDEWALK AND BIKE PATH RAMP
M-4	DRIVEWAY APRON
M-5	PRIVATE PARKING LOT
M-6	CONCRETE WHEEL STOP
M-7	ROAD BARRICADE
M-8	HANDICAP ACCESSIBLE PARKING SPACES
M-9	HANDICAP ACCESSIBLE PARKING SPACES
M-10	HANDICAP SIGN
M-11	REQUIREMENTS FOR AS-BUILT DRAWINGS
M-12	REQUIREMENTS FOR AS-BUILT DRAWINGS
M-13	DUMPSTER PAD
M-14	STREET AND WALKWAY LIGHTS
M-15	STREET AND WALKWAY LIGHTS "THE FLORIDIAN"
M-16	STREET AND WALKWAY LIGHTS "GARDCO LIGHTING"
M-17	STREET AND WALKWAY LIGHTS "LUMEC LIGHTING"
M-18	SIDEWALK CONSTRUCTION AT INTERSECTIONS
M-19	SIDEWALK CONSTRUCTION AT INTERSECTIONS



STANDARD CONSTRUCTION DETAIL  
INDEX  
MISCELLANEOUS DETAILS

FILE NAME:

MISCINDX.DWG

DETAIL REF:

INDEX

## PLAN SHEET REQUIREMENTS:

1. PLANS SUBMITTED TO THE PLANNING DEPARTMENT FOR REVIEW INCLUDING SITE PLANS, SUBDIVISIONS, PLANNED UNIT DEVELOPMENTS, AND OTHER DEVELOPMENTS, SHALL CONSIST OF AT LEAST THE FOLLOWING ITEMS:

- a. INDEX PAGE WITH AREA MAP SHOWING PROJECT LIMITS
- b. PLAN AND PROFILE SHEETS, AS APPROPRIATE
- c. PLAN SHEETS, AS APPROPRIATE
- d. PROFILE SHEETS, AS APPROPRIATE
- e. DETAIL SHEETS, AS APPROPRIATE
- f. OTHER INFORMATION, AS REQUIRED BY LAND DEVELOPMENT CODE

2. THEY SHALL BE DRAWN ON STANDARD 24" X 36" SHEETS. THE PLAN AND PROFILE MAY BE EITHER SINGLE OR DOUBLE AS THE INDIVIDUAL PROJECT DICTATES. EACH SHEET SHALL CONTAIN AN APPROPRIATE TITLE BLOCK SHOWING THE FOLLOWING INFORMATION:

- a. THE NAME OF THE PROJECT
  - b. THE NAME, ADDRESS, AND PHONE NUMBER OF THE COMPANY PREPARING THE DRAWINGS
  - c. THE NAME, ADDRESS, AND PHONE NUMBER OF THE ENGINEER, SURVEYOR, OR LANDSCAPE ARCHITECT AS APPROPRIATE.
  - d. THE SHEET NUMBER
  - e. THE DRAWING NUMBER
  - f. THE DATE
  - g. ANY REVISIONS AND DATE
  - h. OTHER INFORMATION AS APPROPRIATE
3. THE STANDARD SHEET SHALL BE LAID OUT AS SHOWN BELOW, WITH EACH SHEET CONTAINING A NORTH ARROW AND SCALE.

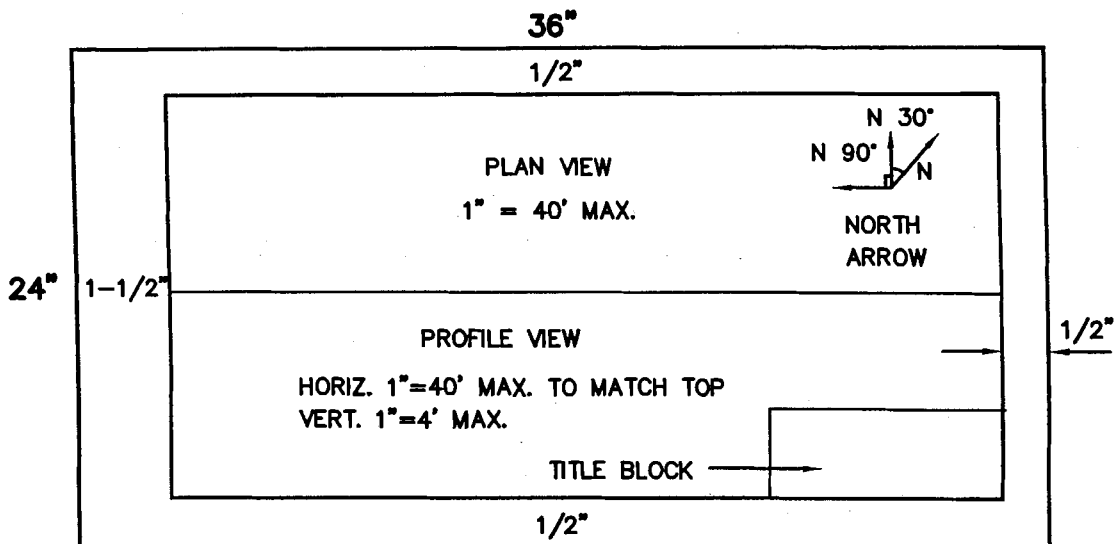

### STANDARD CONSTRUCTION DETAIL PLAN SHEET REQUIREMENTS

FILE NAME:

EW\_M1.DWG

DETAIL REF:

M-1

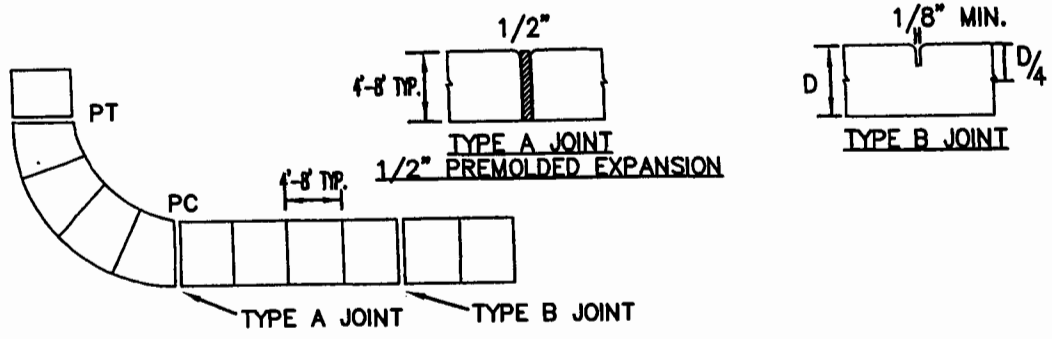

**SIDEWALK CONSTRUCTION REQUIREMENTS**

1. SIDEWALKS, BIKEPATHS, RAMPS, AND DRIVEWAY APRONS SHALL BE CONSTRUCTED OF PLAIN PORTLAND CEMENT CONCRETE WITH A MAXIMUM SLUMP OF 3 INCHES, A MINIMUM DEVELOPED COMPRESSIVE STRENGTH OF 2500 P.S.I. IN 28 DAYS, AND A MINIMUM UNIFORM THICKNESS OF 4 INCHES WHERE INTENDED SOLELY FOR PEDESTRIAN TRAFFIC, AND 6 INCHES THICK WHERE MOTOR VEHICLES ARE LIKELY TO CROSS.
2. SIDEWALKS AND BIKEPATHS SHALL BE PLACED PARALLEL TO, AND ONE FOOT WITHIN THE RIGHT-OF-WAY LINE EXCEPT THAT THE CITY MAY APPROVE DEVIATIONS TO SAVE SPECIMEN TREES PROVIDED THAT THE SIDEWALK REMAINS WITHIN THE RIGHT-OF-WAY OR AN APPROVED SIDEWALK EASEMENT ABUTTING THE RIGHT OF WAY. SIDEWALKS AND BIKE PATHS SHOULD BE LOCATED AT LEAST 4 FEET FROM THE EDGE OF THE STREET PAVEMENT UNLESS OTHERWISE APPROVED BY THE CITY.
3. THE TOP OF THE CONCRETE SHALL BE AT AN ELEVATION NO LOWER THAN THE CROWN OF THE ADJACENT ROADWAY, AND NO HIGHER THAN 6 INCHES ABOVE THE CROWN UNLESS APPROVED BY THE CITY TO MAKE A MORE NATURAL TRANSITION WITH THE ADJACENT LAND.
4. ISOLATION JOINTS (TYPE A JOINTS) SHALL BE INSTALLED SO END PRODUCT IS FLUSH WITH EXISTING AND NEW CONCRETE AS TO PREVENT TRIP HAZARDS , TO SEPARATE PEDESTRIAN SECTIONS FROM SECTIONS WHICH WILL ENCOUNTER VEHICLE TRAFFIC, TO SEPARATE FRESH PLACEMENT FROM CONCRETE WHICH HAS SET FOR MORE THAN 60 MINUTES, AND NO FARTHER APART THAN 100 FEET IN SIDEWALKS AND BIKEPATHS. JOINT MATERIAL SHALL BE AS SPECIFIED IN F.D.O.T. STANDARDS AND SPECIFICATIONS AND SHALL BE RUBBER, PLASTIC OR OTHER APPROVED NON-BIODEGRADABLE ELASTOMERIC MATERIAL. WOOD AND DECCA-DRAIN STYLE POOL DRAINS ARE STRICTLY PROHIBITED.
5. CONTROL JOINTS (TYPE B JOINTS) SHALL BE TOOLED INTO THE FRESH CONCRETE TO A DEPTH EQUAL TO 1/4 THE SLAB THICKNESS AND SPACED APART A DISTANCE EQUAL TO THE WIDTH OF THE SLAB OR 5 FEET WHICHEVER IS GREATEST.
6. THE SLAB SURFACE SHALL BE BROOM FINISHED TO BE SLIP RESISTANT, AND SHALL MATCH AS CLOSELY AS POSSIBLE THE FINISH OF EXISTING ADJACENT SLABS AND ALL EDGES SHALL BE TOOLED TO ELIMINATE SHARP CORNERS.
7. THE BEARING SUBSURFACE SHALL HAVE ALL ORGANIC, LOOSE, AND DELETERIOUS MATTER REMOVED, AND THE REMAINING CLEAN SOIL SHALL BE SMOOTH, SOUND, AND SOLID. ANY FILL MATERIAL SHALL BE COMPACTED WITH A VIBRATORY OR IMPACT COMPACTION MACHINE IN MAXIMUM 12 INCH LIFTS OR COMPACTED WITH A HAND TAMPER IN MAXIMUM 4 INCH LIFTS THE CITY SHALL REQUIRE A COMPACTION TEST FOR EACH LIFT IF THE TOTAL FILLED SECTION IS MORE THAN 12 INCHES DEEP OR IF THE SUBSURFACE HAS BEEN DISTURBED MORE THAN 12 INCHES DEEP. WHERE SUCH TEST IS REQUIRED, THE RESULTS SHALL SHOW A MINIMUM PROCTOR FIELD DENSITY OF 95 PERCENT.
8. ALL CONCRETE WORK IN THE RIGHT-OF-WAY SHALL BE INSPECTED BY THE CITY AFTER THE SUBSOIL IS PREPARED AND THE FORMS ARE SET, BUT BEFORE THE CONCRETE PLACEMENT BEGINS.
9. THE CONTRACTOR SHALL BE RESPONSIBLE FOR PROTECTING THE FINISHED SLAB FROM ALL DAMAGE AND VANDALISM UNTIL THE CITY ACCEPTS OR APPROVES THE SLAB, AFTER WHICH TIME THE OWNER OF THE ABUTTING LAND SHALL BE RESPONSIBLE FOR THE SLAB IN ACCORDANCE WITH THE CITY CODE. ANY SLAB SECTION DAMAGED OR VANDALIZED PRIOR TO ACCEPTANCE OR APPROVAL SHALL BE CUT OUT BETWEEN JOINTS AND REPLACED. REPAIRS ARE NOT ACCEPTABLE.
10. SIDEWALKS LOCATED WITHIN THE RIGHT-OF-WAY SHALL NOT BE TINTED, STAINED, COLORED, OR COATED.
11. ALL FORMS SHALL BE REMOVED PRIOR TO ACCEPTANCE OR APPROVAL AND THE DISTURBED GROUND SHALL BE BACKFILLED, REGRADED, AND SODDED SO THAT THE WEAR SURFACE OF THE CONCRETE IS REASONABLY FLUSH WITH THE ADJACENT GRADE.



**STANDARD CONSTRUCTION DETAIL  
SIDEWALK CONSTRUCTION REQUIREMENTS**

**FILE NAME:**  
EW\_M2.DWG

**DETAIL REF:**  
**M-2**

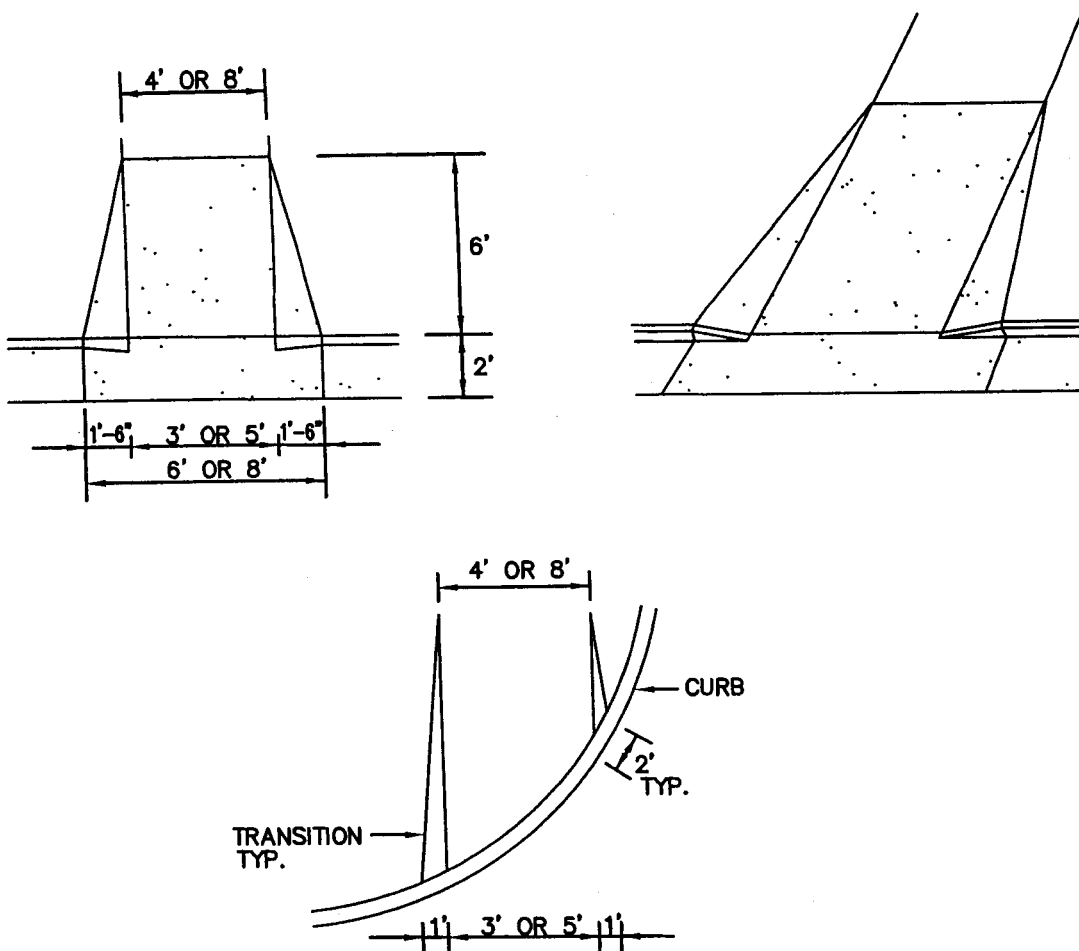

**NOTES:**

1. RAMP LOCATIONS ARE TO BE COORDINATED WITH AND IN CONFORMANCE WITH CROSSWALK MARKING DETAILS SHOWN IN THE PLANS.
2. CURBED RAMPs SHALL HAVE FLARED SIDES WITH A MAXIMUM SLOPE OF 12:1.
3. RAMPs SHALL HAVE A TACTLIKE SURFACE, TEXTURED TO A DEPTH NOT EXCEEDING 1/8".
4. RAMPs ARE TO BE CONSTRUCTED AT ALL LOCATIONS SHOWN IN THE PLANS EVEN WHEN A SIDEWALK IS NOT CONSTRUCTED CONCURRENTLY.
5. NO CURB TRANSITION IS NEEDED FOR MIAMI CURBS.
6. ALL RAMPs SHALL BE CONSTRUCTED IN ACCORDANCE WITH FDOT INDEX NO. 304 AND HANDICAPPED ACCESSIBILITY REQUIREMENTS IN ACCORDANCE WITH THE AMERICAN DISABILITIES ACT.



**STANDARD CONSTRUCTION DETAIL  
SIDEWALK AND BIKEPATH RAMP**

**FILE NAME:**

EW\_M3.DWG

**DETAIL REF:**

**M-3**

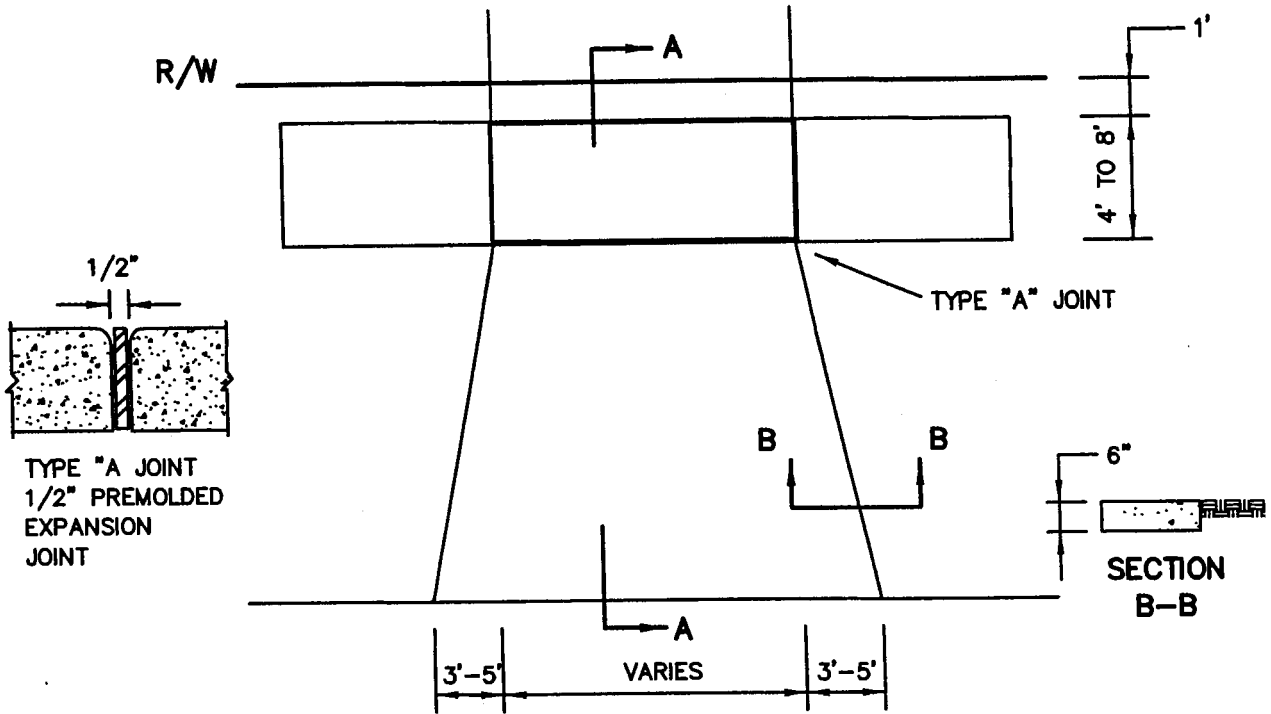

**PLAN**

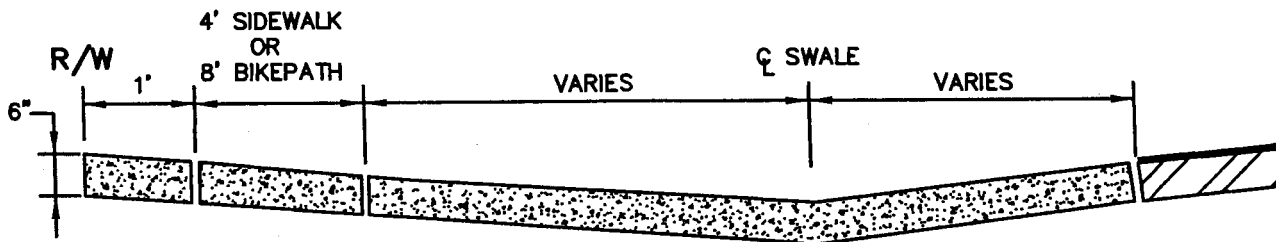

**RURAL SECTION**

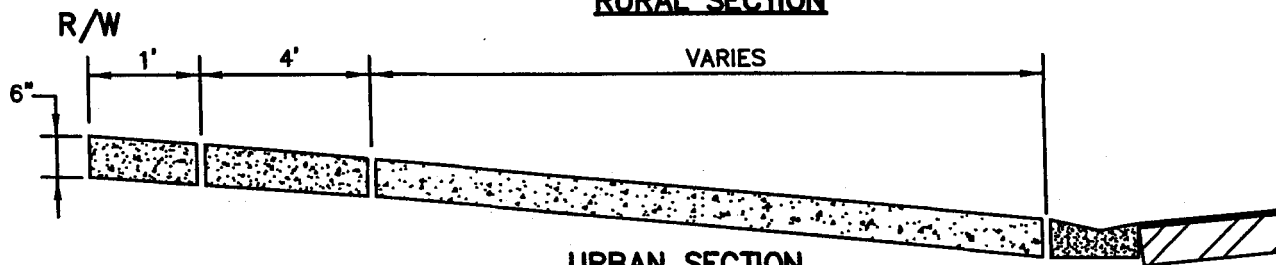

**URBAN SECTION**

**(SECTION A-A)**

**NOTES:**

1. DRIVEWAY APRON BASE TO BE COMPACTED AND TESTED TO 98% DENSITY WITH MINIMUM L.B.R. 40 BASED ON AASHTO T-180 MODIFIED PROCTOR TEST.
2. CONCRETE DRIVEWAY APRON TO BE 28 DAY, 3000 P.S.I.
3. DRIVEWAY WIDTHS OF 14' OR MORE SHALL HAVE A CONTROL JOINT LENGTH-WISE.



**STANDARD CONSTRUCTION DETAIL  
DRIVEWAY APRON**

FILE NAME:

EW\_M4.DWG

DETAIL REF:

**M-4**

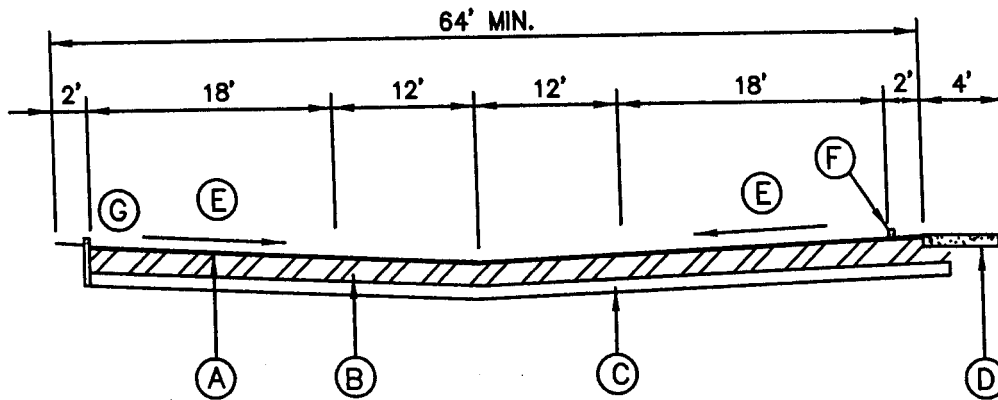

(A) ASPHALT PAVEMENT:  
 1-1/4" ASPHALT BITUMINOUS CONCRETE TYPE S-III; MINIMUM MARSHALL FIELD STABILITY 1500, COMPACTED TO 98% DENSITY PER FM 1-T238 (METHOD B), NUCLEAR DENSITY TEST, "BACK SCATTER METHOD".

(B) BASE:  
 6" SOIL CEMENT BASE MINIMUM BEARING STRUCTURE OF 350 P.S.I. SHALL BE OBTAINED WITHIN 7 DAYS AND COMPACTED TO 98% DENSITY PER AASHTO T-99 STANDARD PROCTOR TEST; CONSTRUCTION METHODS SHALL CONFORM TO SECTION 270 OF STANDARD F.D.O.T. SPECIFICATIONS FOR ROAD AND BRIDGE CONSTRUCTION, LATEST EDITION.

ALTERNATE:

6" LIMEROCK BASE (LBR 100) OR RECYCLED CONCRETE BASE (LBR 130) COMPACTED TO 98% DENSITY BASED ON AASHTO T-180 MODIFIED PROCTOR TEST.

(C) SUB-BASE:  
 6" SUB-BASE COMPACTED TO 98% DENSITY BASED ON AASHTO T-180 MODIFIED PROCTOR TEST WITH MINIMUM LBR 40.

(D) 4'-0" WIDE, 4" THICK, CONCRETE SIDEWALK, 3000 P.S.I.

(E) THE MINIMUM ALLOWABLE PARKING LOT PAVEMENT SLOPE FOR ASPHALT SHALL BE NO LESS THAN 0.75% MEASURED FROM THE RECEIVING INLET OR FLUME TO ANY PAVEMENT. (NOTE THAT THE MINIMUM SLOPE MAY BE REDUCED TO 0.50% FOR CONCRETE PAVEMENT.)

(F) CONCRETE WHEEL STOP.

(G) 6" HEADER CURB WITH 1'-6" OF SODDED OVERHANG

**NOTES:**

1. ALL MATERIALS ARE TO BE APPROVED BY THE CITY'S DESIGNATED SITE INSPECTOR AND THE DEVELOPER'S LICENSED SOILS ENGINEER PRIOR TO PLACEMENT.
2. A REPRESENTATIVE OF A CERTIFIED SOIL LABORATORY SHALL BE PRESENT DURING ALL CONSTRUCTION PHASES UTILIZING A SOIL CEMENT BASE. THE REPRESENTATIVE SHALL BE CERTIFIED BY F.D.O.T. IN THE INSTALLATION OF SOIL CEMENT.



**STANDARD CONSTRUCTION DETAIL  
 PRIVATE PARKING LOT**

FILE NAME:

EW\_M5.DWG

DETAIL REF:

M-5

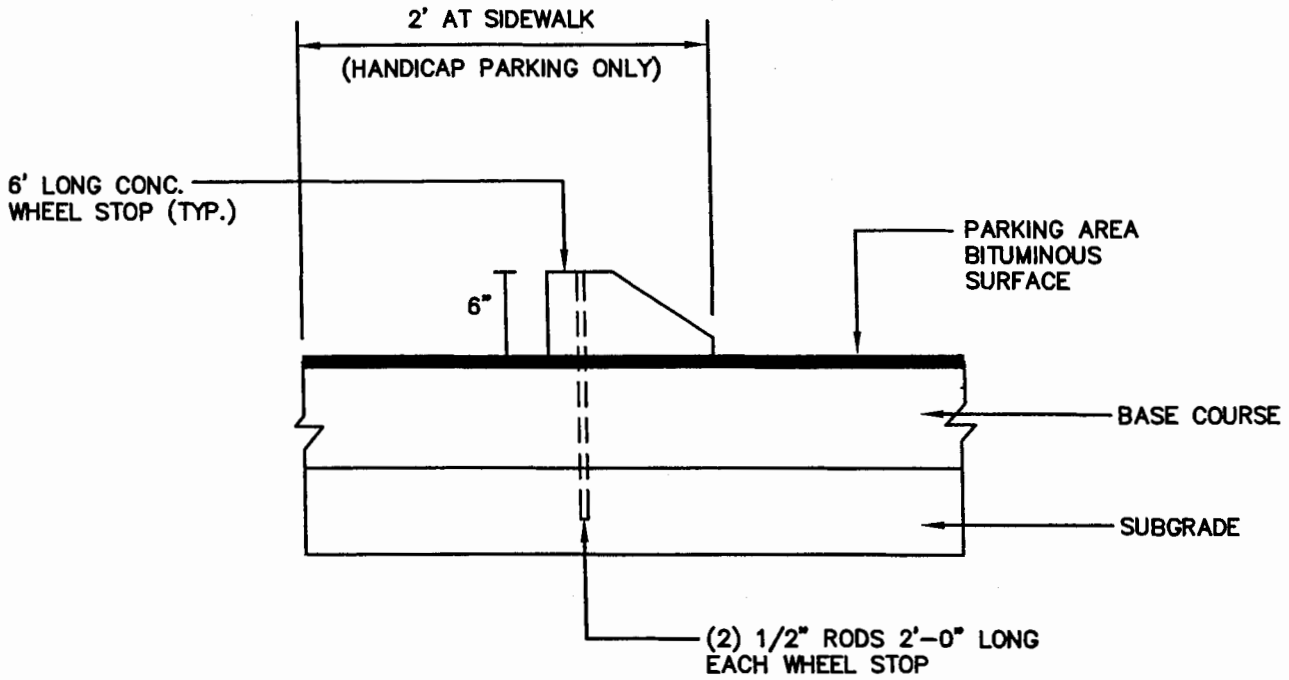

**NOTE:**

1. CENTER WHEEL STOP IN EACH STALL



**STANDARD CONSTRUCTION DETAIL  
CONCRETE WHEELSTOP**

FILE NAME:

EW\_M6.DWG

DETAIL REF:

M-6

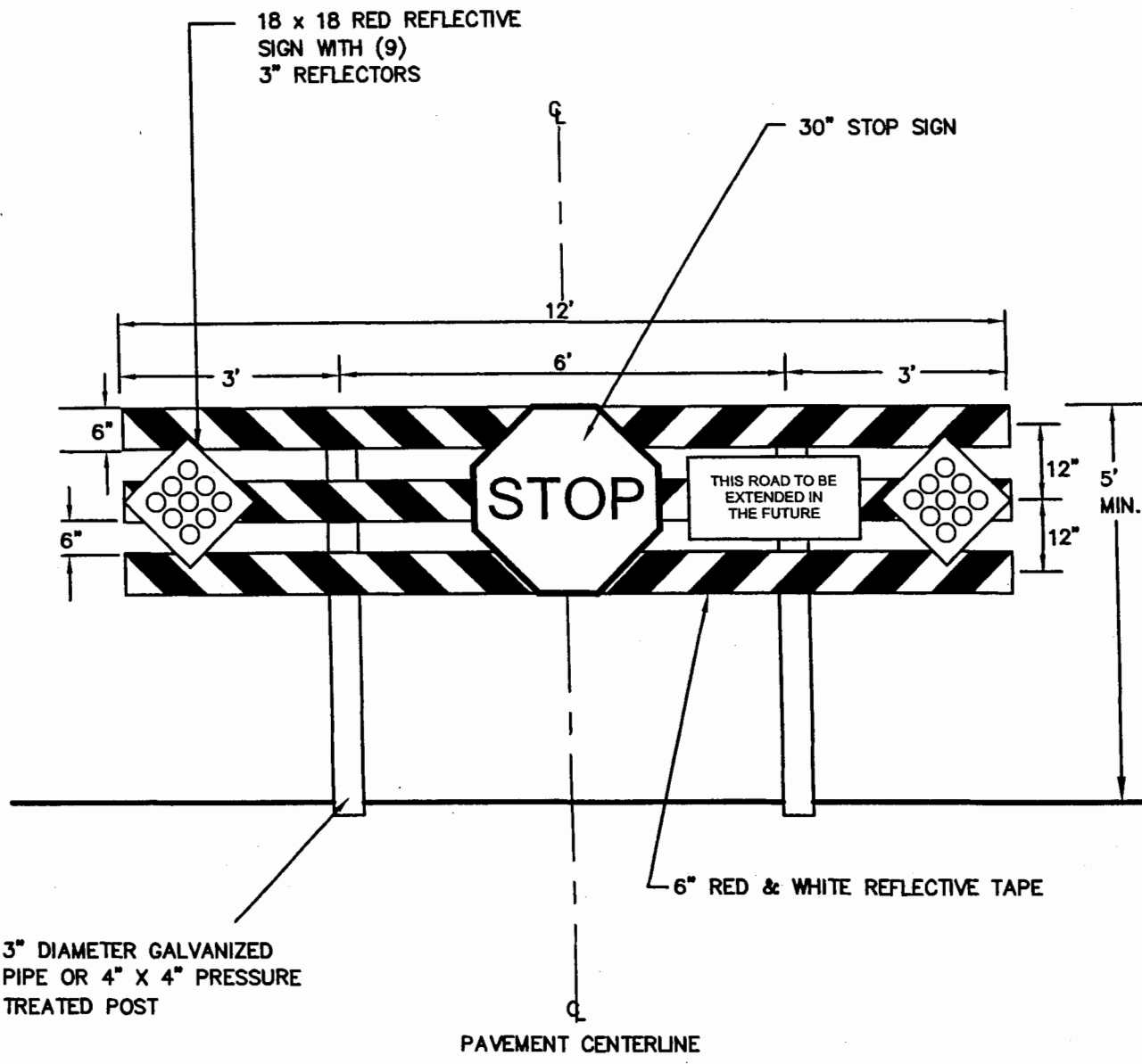

**STANDARD CONSTRUCTION DETAIL  
ROAD BARRICADE**

FILE NAME:

EW\_M7.DWG

DETAIL REF:

**M-7**

**HANDICAP ACCESSIBLE PARKING SPACES SHALL BE PROVIDED IN ACCORDANCE WITH CURRENT FLORIDA STATUTES, INCLUDING THE FOLLOWING DETAILS:**

1. ANY COMMERCIAL REAL ESTATE PROPERTY OWNER OFFERING PARKING FOR THE GENERAL PUBLIC SHALL PROVIDE SPECIALLY DESIGNED AND MARKED MOTOR VEHICLE PARKING SPACES FOR THE EXCLUSIVE USE OF PHYSICALLY DISABLED PERSONS WHO HAVE BEEN ISSUED PARKING PERMITS PURSUANT TO STATE LAW.
2. DIAGONAL OR PERPENDICULAR PARKING SPACES SHALL BE A MINIMUM OF 12 FEET WIDE (SEE FIGURE 1).
3. PARALLEL PARKING SPACES SHALL BE LOCATED EITHER AT THE BEGINNING OR END OF A BLOCK OR ADJACENT TO ALLEY ENTRANCES (SEE FIGURE 2). CURBS ADJACENT TO SUCH SPACES SHALL BE OF A HEIGHT WHICH WILL NOT INTERFERE WITH THE OPENING AND CLOSING OF MOTOR VEHICLE DOORS.
4. EACH SUCH PARKING SPACE SHALL BE CONSPICUOUSLY OUTLINED IN BLUE PAINT AND SHALL BE POSTED AND MAINTAINED WITH A PERMANENT, ABOVE-GRADE SIGN BEARING THE INTERNATIONAL SYMBOL OF ACCESSIBILITY AND THE CAPTION PARKING BY DISABLED PERMIT ONLY, AND AN ADDITIONAL SIGN STATING THE PENALTY FOR ILLEGAL USE OF THE SPACE (SEE FIGURE 2). SUCH SIGNS SHALL NOT BE OBSCURED BY A VEHICLE PARKED IN THE SPACE. ALL HANDICAP ACCESSIBLE PARKING MUST BE SIGNED AND MARKED IN ACCORDANCE WITH THE STANDARDS ADOPTED BY THE FLORIDA DEPARTMENT OF TRANSPORTATION.
5. ALL SPACES SHALL HAVE A SIXTY INCH (60") WIDE ADJACENT ACCESS AISLE (SEE FIGURE 2). PARKING ACCESS AISLES SHALL BE PART OF THE ACCESSIBLE ROUTE TO THE BUILDING OR FACILITY ENTRANCE. TWO ACCESSIBLE PARKING SPACES MAY SHARE A COMMON ACCESS AISLE. PARKED VEHICLE OVERHANGS SHALL NOT REDUCE THE CLEAR WIDTH OF AN ACCESSIBLE CIRCULATION ROUTE.
6. ALL SPACES SHALL HAVE AN ACCESSIBLE CURB-RAMP OR CURB-CUT TO ALLOW ACCESS TO THE BUILDING SERVED. IT SHALL BE LOCATED SO THAT USERS WILL NOT BE COMPELLED TO WHEEL BEHIND PARKED VEHICLES.
7. THE MINIMUM NUMBER OF SUCH PARKING SPACES SHALL COMPLY WITH THE FOLLOWING TABLE:

TOTAL PARKING IN LOT	REQUIRED NUMBER OF ACCESSIBLE SPACES
UP TO 25.....	1
26 TO 50.....	2
51 TO 75.....	3
76 TO 100.....	4
101 TO 150.....	5
151 TO 200.....	6
201 TO 300.....	7
301 TO 400.....	8
401 TO 500.....	9
501 TO 1000.....	2% OF TOTAL
OVER 1000.....	20 PLUS 1 FOR EACH 100 OVER 1000

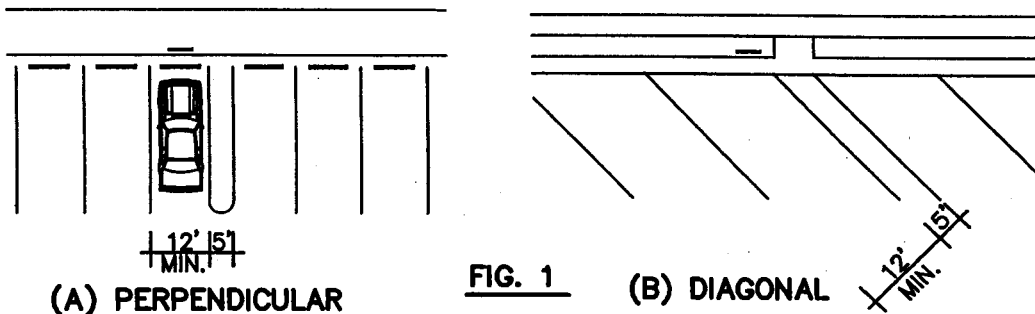

**STANDARD CONSTRUCTION DETAIL**  
**HANDICAP ACCESSIBLE PARKING SPACES**

FILE NAME:

EW\_M8.DWG

DETAIL REF:

**M-8**

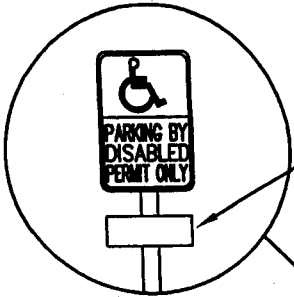

\$100 FINE  
-OR-  
\$100 PENALTY FOR ILLEGAL USE

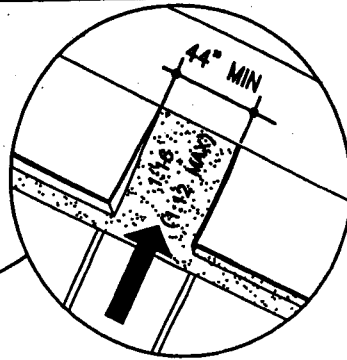

HANDICAP ACCESSIBLE PARKING SIGN LOCATION (TYP.)

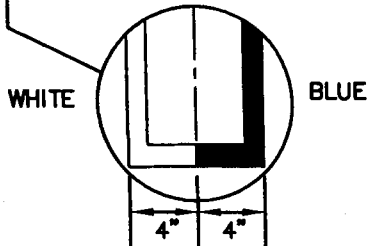
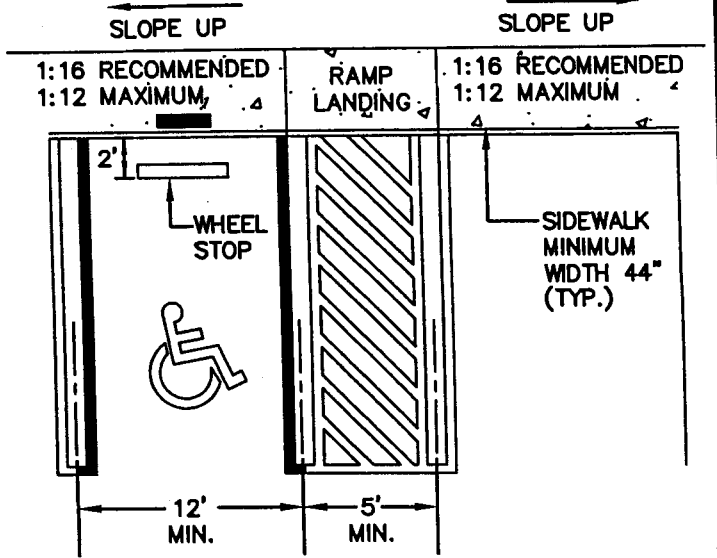
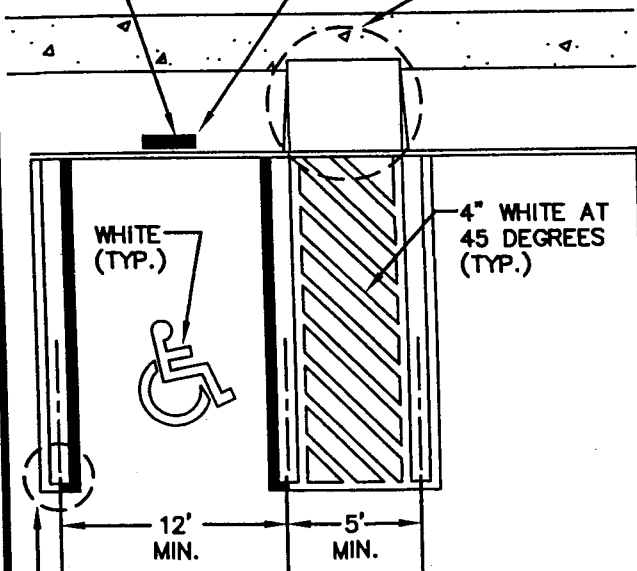
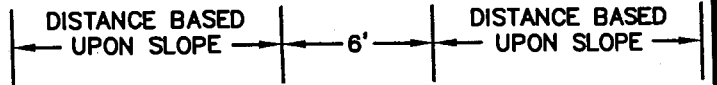

ACCESSIBLE PARKING SPACES AND ACCESS AISLES SHALL BE LEVEL WITH SURFACE SLOPES NOT EXCEEDING 1:50 (2%) IN ALL DIRECTIONS

**SIDEWALK RAMP DETAIL**

**SIDEWALK ABUTTING PARKING LOT DETAIL**

**NOTE:**

1. WHEN HEADER CURB IS USED IN LIEU OF WHEEL STOPS, SIDEWALK ABUTTING CURB MUST BE WIDENED BY 18" SO THAT THE TOTAL SIDEWALK WIDTH IS 62", ALLOWING FOR 44" MINIMUM CLEAR ACCESSIBLE ROUTE.
2. FOR COMPLETE DETAIL OF HANDICAPPED SIGN, REFER TO DETAIL M-10.



**STANDARD CONSTRUCTION DETAIL  
HANDICAP ACCESSIBLE PARKING SPACES**

FILE NAME:

EW\_M9.DWG

DETAIL REF:

**M-9**

1'-0"X1'-6"X.080 ALUMINUM HANDICAPPED  
PARKING SIGN. SIGN TO READ "PARKING  
BY DISABLED PERMIT ONLY". BOLT TO  
STEEL TUBE WITH 2 1/8" CADMIUM  
PLATED BOLTS, NUTS AND WASHERS

\$100 FINE SIGN

VAN-ACCESSIBLE SIGN

2"X2"X.188 STEEL TUBE EXTENDED INTO  
CONCRETE FILLED PIPE 2'-0". PROVIDE  
WELDED WATERTIGHT CAP. PAINT P&L  
#6118 BLACK COFFEE

PAINT PIPE BASE YELLOW

PAVEMENT/SIDEWALK

CONCRETE



1'-6"

84"

**NOTE:**

1. HANDICAPPED PARKING SIGN SHALL CONFORM WITH CURRENT STATE AND LOCAL AND FEDERAL CODES AND REGULATIONS.
2. ALL SIGNS SHALL BE DESIGNED TO WITHSTAND 100 M.P.H. WINDLOAD.



**STANDARD CONSTRUCTION DETAIL  
HANDICAP SIGN**

FILE NAME:

EW\_M10.DWG

DETAIL REF:

M-10

## REQUIREMENTS FOR AS-BUILT DRAWINGS

IN ORDER TO ENSURE THAT NEW SUBDIVISIONS AND SITE PLANS ARE CONSTRUCTED SUBSTANTIALLY IN ACCORDANCE WITH CITY REGULATIONS AND THE APPROVED DRAWINGS, THE FOLLOWING INFORMATION IS REQUIRED ON ALL SUBDIVISION AS-BUILT DRAWINGS.

1. PAVEMENT AND CURB WIDTHS SHALL BE VERIFIED AND DIMENSIONED FOR EACH STREET AT EACH BLOCK. (FOR SUBDIVISIONS) AND AS APPROPRIATE TO CONFIRM PAVING LIMITS (ON SITE PLANS).
2. ALL RADII AT INTERSECTIONS SHALL BE VERIFIED AND DIMENSIONED. THIS INFORMATION IS TO BE CLEARLY INDICATED ON THE AS-BUILT.
3. ROADWAY ELEVATIONS SHALL BE RECORDED AT ALL GRADE CHANGES, 100' INTERVALS ALONG ROADWAY, AND OTHER INTERVALS AS NEEDED ALONG ALL STREETS. STREET CENTERLINE AND CURB INVERT ELEVATIONS SHALL BE RECORDED AS NOTED. THE AS-BUILT CENTERLINE PROFILE OF ALL STREETS SHALL ALSO BE SHOWN ON THE PLAN AND PROFILE SO IT MAY BE COMPARED TO THE DESIGN PROFILE GRADE LINES. IN THE EVENT THAT THE AS-BUILT CENTERLINE LONGITUDINAL GRADE DOES NOT MEET THE CITY MINIMUM STANDARDS, ADDITIONAL LONGITUDINAL GRADES OF THE ADJACENT CURBING AND SIMILAR ROADWAY CROSS-SECTION SURVEYS TO VERIFY THE CORRECT CROSS SLOPE, SHALL BE REQUIRED TO VERIFY THAT THE SYSTEM WILL FUNCTION AS ORIGINALLY DESIGNED.
4. STORM DRAINAGE STRUCTURES SHALL BE LOCATED AND / OR DIMENSIONED FROM CENTERLINES OR LOT LINES AS APPROPRIATE.
5. STORM DRAINAGE PIPE INVERT AND INLET ELEVATIONS SHALL BE RECORDED AND CLEARLY DENOTED AS AS-BUILT INFORMATION. DESIGN ELEVATIONS SHALL BE CROSSED OUT AND AS-BUILT INFORMATION WRITTEN NEXT TO IT.
6. STORM DRAINAGE PIPE MATERIAL, LENGTH, AND SIZE SHALL BE MEASURED AND / OR VERIFIED. THIS INFORMATION IS TO BE CLEARLY INDICATED AS BEING AS-BUILT INFORMATION .
7. ALL APPLICABLE TOPOGRAPHIC INFORMATION PERTINENT TO THE ON-SITE DRAINAGE SYSTEM, SUCH AS DITCHES, SWALES, LAKES, CANALS, ETC. THAT ARE DEEMED NECESSARY BY THE CITY TO VERIFY THE FUNCTIONAL PERFORMANCE OF THE STORMWATER SYSTEM, SHALL BE NOTED. NORMALLY, RECORDING ELEVATIONS EVERY 100 FEET AT THE TOP OF BANK AND TOE OF SLOPE WILL BE REQUIRED. MEASUREMENTS SHALL BE TAKEN AND RECORDED IN ORDER TO ACCURATELY TIE DOWN THESE FEATURES TO THE ROADWAY CENTERLINES AND TO PLAT LINES. WHENEVER POSSIBLE, CONTOUR LINES SHALL BE UTILIZED TO GRAPHICALLY DESCRIBE THESE TOPOGRAPHIC FEATURES .
8. RETENTION AREAS SHALL HAVE THEIR TOP-OF BANK AND BOTTOM ELEVATIONS RECORDED. ACTUAL MEASUREMENTS SHALL BE TAKEN AND DIMENSIONS RECORDED OF THE SIZE OF ALL RETENTION AREAS. MEASUREMENTS SHALL BE DONE FROM TOP-OF-BANK TO TOP-OF-BANK WITH SIDE SLOPES INDICATED. SEPARATE CALCULATIONS SHALL BE SUBMITTED TO INDICATE REQUIRED AND PROVIDED RETENTION VOLUMES.
9. ACTUAL MATERIALS USED AND ELEVATIONS AND DIMENSIONS OF OVERFLOW WEIR STRUCTURES AND SKIMMERS SHALL BE NOTED ON THE AS-BUILT.
10. STORM DRAINAGE SWALE CENTERLINES SHALL BE LOCATED AND ELEVATIONS OF FLOW LINE AND TOP OF BANK SHALL BE RECORDED EVERY 100 FEET. SIDE SLOPES SHALL ALSO BE INDICATED.
11. SANITARY SEWER MANHOLES SHALL BE VERIFIED AND DIMENSIONED FROM STREET CENTERLINES OR LOT LINES AS APPROPRIATE. ALL RIM AND INVERT ELEVATIONS SHALL BE VERIFIED AND RECORDED. THIS INFORMATION SHALL BE CLEARLY INDICATED AS BEING AS-BUILT INFORMATION. DESIGN ELEVATIONS SHALL BE CROSSED OUT AND AS-BUILT INFORMATION WRITTEN NEXT TO IT.
12. FOR SUBDIVISIONS, PROPOSED DESIGN FINISHED FLOOR ELEVATIONS SHALL APPEAR ON ALL SUBDIVISION LOTS ON THE APPROPRIATE PLAN AND PROFILE SHEET AS WELL AS ON THE MASTER DRAINAGE PLAN.



### STANDARD CONSTRUCTION DETAIL REQUIREMENTS FOR AS-BUILT DRAWINGS

FILE NAME:

EW\_M11.DWG

DETAIL REF:

M-11

**REQUIREMENTS FOR AS-BUILT DRAWINGS**  
**(CONTD.)**

13. SANITARY SEWER LINE LENGTHS, SIZES, MATERIAL, ETC., SHALL BE VERIFIED AND RECORDED. THIS INFORMATION IS TO BE CLEARLY INDICATED AS BEING AS-BUILT INFORMATION.
14. SEWER LATERALS SHALL BE VERIFIED AND RECORDED AT THEIR CLEAN-OUT LOCATIONS. STATIONING AND OFFSET DISTANCES SHALL BE MEASURED FROM DOWNSTREAM MANHOLES TOWARDS UPSTREAM MANHOLES.
15. LIFT STATIONS AND FORCE MAINS SHALL BE VERIFIED AND DIMENSIONED FROM STREET CENTERLINES OR LOT LINES AS APPROPRIATE. FORCE MAIN DEPTH AND LOCATION INCLUDING VALVES WILL BE PROVIDED AND TIED TO PERMANENT ABOVE GRADE FEATURES. DIMENSIONAL AND ELEVATION INFORMATION INDICATED ON THE APPROVED PLAN SHALL BE VERIFIED AND RECORDED. THIS INFORMATION SHALL BE CLEARLY INDICATED AS BEING AS-BUILT INFORMATION. BURIED ELECTRICAL SERVICE LINE SHALL BE CLEARLY DIMENSIONED, LOCATED, AND LABELED.
16. CURB CUTS OR METAL TABS, USED TO MARK SEWER LATERALS, WATER SERVICES AND WATER VALVES, SHALL BE VERIFIED FOR PRESENCE AND ACCURACY OF LOCATION.
17. POTABLE AND RECLAIMED WATER MAIN LINES SHALL BE DIMENSIONED OFF THE BACK OF CURB, OR EDGE OF PAVEMENT IF NO CURB IS PRESENT. WATER MAIN LINE MATERIAL SIZE, LENGTH AND DEPTH PLACED SHALL ALSO BE NOTED. LOCATIONS OF VALVES SHALL BE TIED TO PERMANENT ABOVE GRADE FEATURES. THIS INFORMATION SHALL BE CLEARLY INDICATED AS BEING AS-BUILT INFORMATION.
18. POTABLE AND RECLAIMED WATER VALVES, TEES, BENDS, ALL SERVICES, AND FIRE HYDRANTS SHALL BE LOCATED BY TYING THEM TO SANITARY SEWER MANHOLES. SIMILARLY, FORCE MAIN VALVES, TEES, AND BENDS SHALL BE LOCATED IN THE SAME MANNER. STATIONING AND OFFSET DISTANCES SHALL BE MEASURED FROM DOWNSTREAM MANHOLES TO UPSTREAM MANHOLES.
19. FOR PERPENDICULAR CROSSINGS OF STORMWATER, SANITARY SEWER, POTABLE WATER, OR RECLAIMED WATER, THE AS-BUILT PLANS SHALL CLEARLY INDICATE WHICH UTILITIES ARE LOCATED OVER OR UNDER OTHER UTILITIES, AS NECESSARY.
20. ANY SPECIAL FEATURES SUCH AS, CONCRETE FLUMES, LAKE BANKS, WALLS, FENCING, ETC., WHICH WERE A PART OF THE APPROVED CONSTRUCTION DRAWINGS SHOULD ALSO BE LOCATED AND DIMENSIONED.
21. IF AN APPROVED SUBDIVISION PLAT OR SITE PLAN SHOWS A CONSERVATION EASEMENT, THE PROJECT SURVEYOR SHOULD PROVIDE THE EXACT LOCATION OF THE SPECIMEN TREE(S) FROM THE RIGHT-OF-WAY OR PROPERTY LINES AND PROPOSED EASEMENT BOUNDARIES ON THE AS-BUILT DRAWING. THE AS-BUILT LOCATION OF THESE TREES WILL HELP VERIFY THE SUFFICIENCY OF THE CONSERVATION EASEMENT PRIOR TO PLAT RECORDING OR CERTIFICATE OF OCCUPANCY.
22. WHEN STORMWATER, POTABLE WATER, RECLAIMED WATER, OR SANITARY SEWER IMPROVEMENTS ARE ARE LOCATED WITHIN AN EASEMENT, THE AS-BUILT DRAWING SHALL ACCURATELY DEPICT THE LOCATION OF THE EASEMENT ITSELF AS WELL AS THE EXACT LOCATION OF THE IMPROVEMENTS WITHIN THE EASEMENT. THIS IS REQUIRED IN ORDER TO VERIFY THAT THE IMPROVEMENTS HAVE BEEN PROPERLY LOCATED AND TO ENSURE THAT FUTURE SUBSURFACE EXCAVATION TO PERFORM REMEDIAL REPAIR CAN BE ACCOMPLISHED WITHOUT DISTURBANCE BEYOND THE EASEMENT.

**NOTE:**

1. REFERENCES TO WATER SHALL MEAN BOTH POTABLE AND RECLAIMED WATER.



**STANDARD CONSTRUCTION DETAIL**  
**REQUIREMENTS FOR AS-BUILT**  
**DRAWINGS**

**FILE NAME:**

**EW\_M12.DWG**

**DETAIL REF:**

**M-12**

(4) 4" DIAMETER STEEL PIPES, 4' O.C. CONCRETE FILLED, PAINTED YELLOW. PIPES SHALL HAVE A MINIMUM BURIAL OF 1'-6" AND ABOVE GROUND HEIGHT OF 3'-6".

DECORATIVE WALL OR 6' HIGH STOCKADE FENCE CONSISTING OF ONE OR MORE COLORS AND FINISHES TO BE COMPLEMENTARY TO BUILDING DESIGN.

ENCLOSED ON 3 SIDES

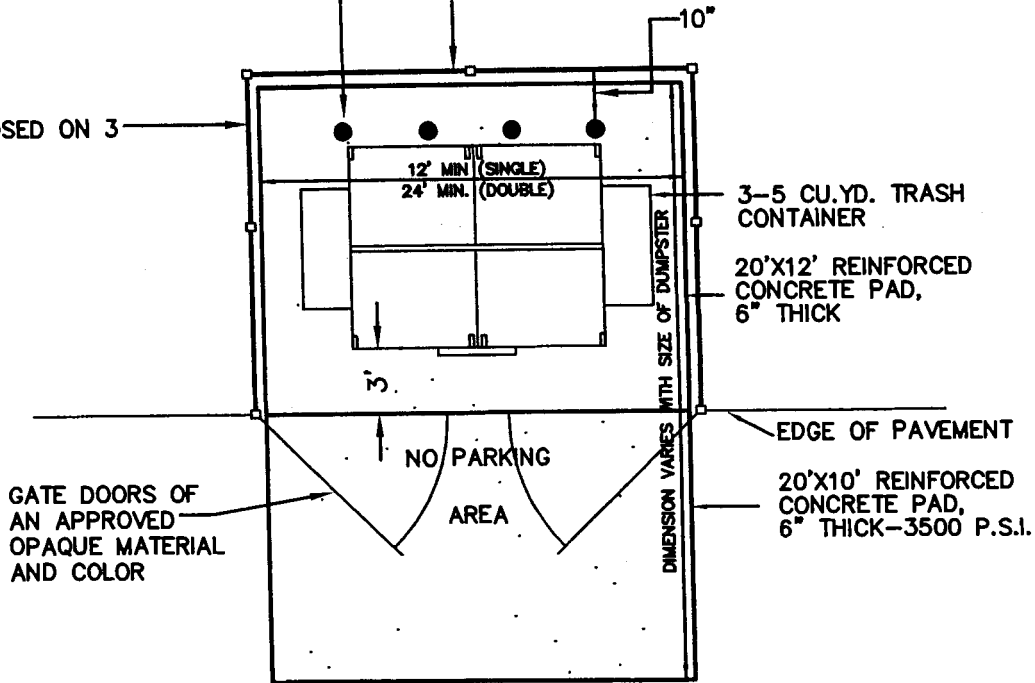

PLAN

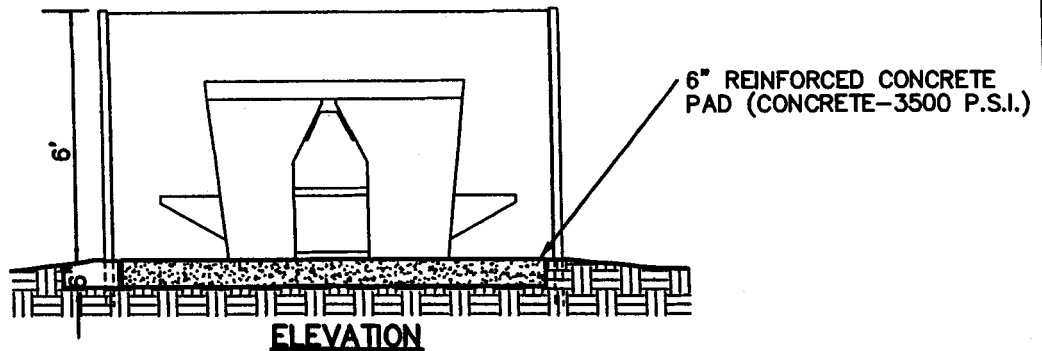

ELEVATION

**NOTES:**

1. MAXIMUM ANGLE OF CONTAINER PAD TO DIRECTION OF AISLE TO BE 30°
2. AREA TO BE FREE OF OVERHEAD LINES AND WIRES.
3. DUMPSTER PAD TO BE 12' MIN. (SINGLE) 24' MIN (DOUBLE) FOR DUMPSTER RECYCLING.
4. APPLICANT TO PROVIDE A SIDE ELEVATION TO DEMONSTRATE COLOR, MATERIAL, AND DESIGN CONSISTENCY WITH THE PRINCIPAL BUILDING.



**STANDARD CONSTRUCTION DETAIL  
DUMPSTER PAD**

FILE NAME:

EW\_M13.DWG

DETAIL REF:

M-13

## STREET AND WALKWAY LIGHTS

### WALKWAY LIGHTS: (HEIGHT: 10 TO 20 FEET)

1. WALKWAY LIGHTING SHALL BE PROVIDED IN ALL PUBLIC PARKING AND WALKWAY AREAS. LIGHT STYLES AND SPACING SHALL BE DETERMINED BY THE COMMUNITY DEVELOPMENT DEPT. AT THE SAME TIME OF SITE PLAN REVIEW.
2. UNLESS SPECIFIED OTHERWISE, THE WALKWAY LIGHTS SHALL BE ANY OF THE THREE (3) STYLES DETAILED HEREIN OR THE FOLLOWING: STERNBERG GEORGETOWN (0650 / 4408-DFP), WILLIAMSBURG (9405-TF / 3610-T) OR COLONIAL (4620TF-LF). ALL CITY MAINTAINED WALKWAY LIGHTS ARE TO BE FLORIDA POWER AND LIGHT (FPL) SUPPLIED LIGHTS, UTILIZING 150 WATT HPS.
4. SPACING SHALL BE A MAXIMUM OF 100 FEET ON CENTER.

### STREET LIGHTS: (HEIGHT: 20+ FEET)

1. ALL CITY MAINTAINED STREET LIGHTS ARE TO BE FPL SUPPLIED STREET LIGHTS.
2. PRIVATELY MAINTAINED STREET LIGHTS SHALL BE:  
GARDCO LIGHTING EH / 26" / 1 / 3 / 150 HPS / 240 / BRA / PC  
(NOTE: POLE SHALL BE CONCRETE AVAILABLE THROUGH F.P.L. AND SPACED AT INTERVALS OF 300 TO 400 FEET.)



### STANDARD CONSTRUCTION DETAIL STREET AND WALKWAY LIGHTS

FILE NAME:

EW\_M14.DWG

DETAIL REF:

M-14

## THE FLORIDIAN

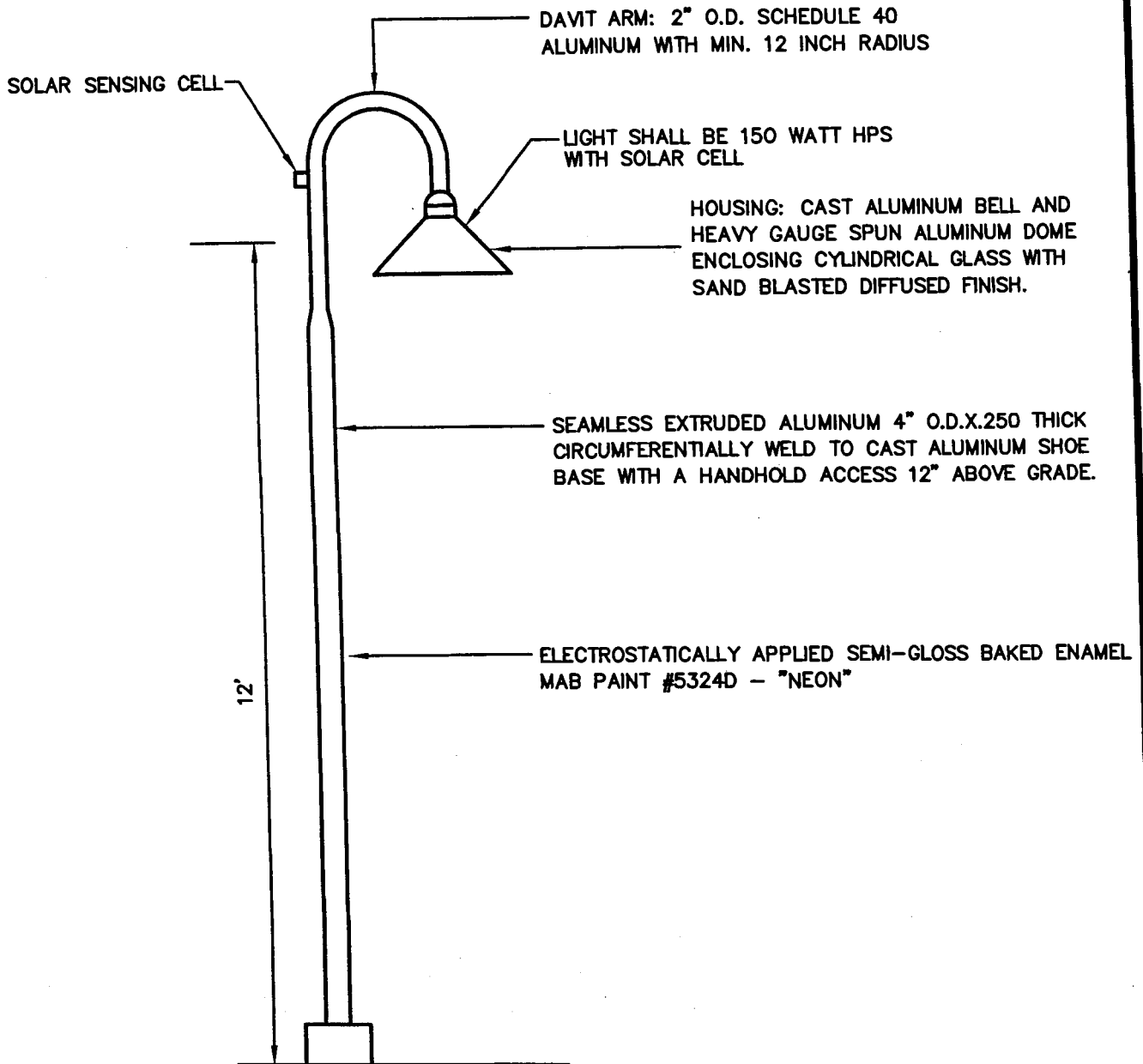

### **NOTE:**

1. ALL WALKLIGHTS SHALL BE FITTED WITH SOLAR CELLS AND LOCATED ON 100' CENTERS. THE PLANNING DIVISION SHALL BE CONTACTED AT (386) 424-2412 TO FIELD VERIFY THE PROPOSED LOCATIONS FOR WALKLIGHTS. MAINTENANCE AND OPERATION OF WALKLIGHTS SHALL BE GRANTED TO THE CITY FOLLOWING INSTALLATION AND OPERATION, TO THE CITY'S FULL SATISFACTION.
2. ALL LIGHT POLES SHALL BE DESIGNED TO WITHSTAND 120 M.P.H. WINDLOADS



### **STANDARD CONSTRUCTION DETAIL STREET AND WALKWAY LIGHTS "THE FLORIDIAN"**

FILE NAME:

EW\_M15.DWG

DETAIL REF:

**M-15**

## GARDCO LIGHTING

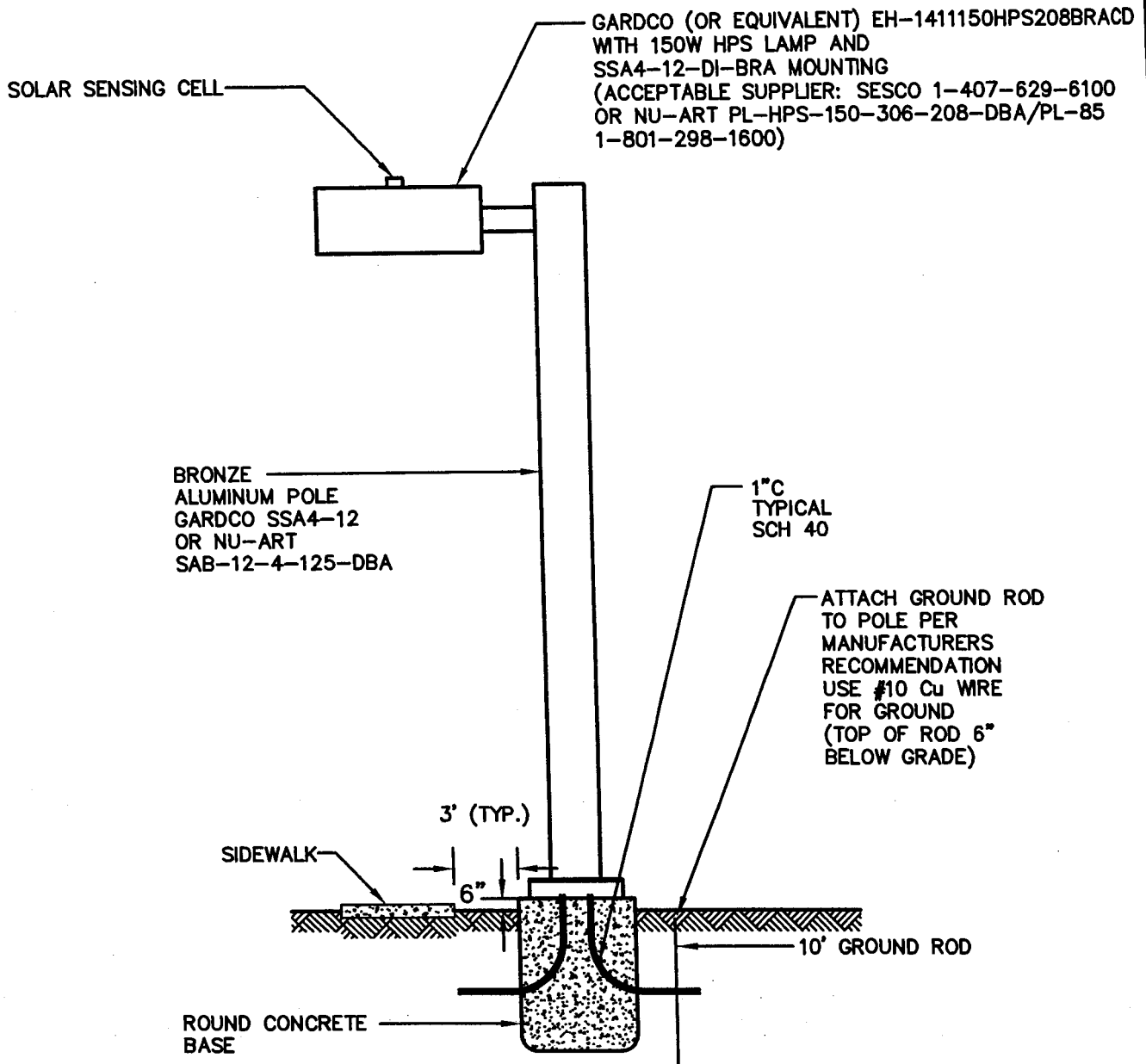

**NOTE:**

1. ALL WALKLIGHTS SHALL BE FITTED WITH SOLAR CELLS AND LOCATED ON 100' CENTERS. THE PLANNING DIVISION SHALL BE CONTACTED AT (386) 424-2412 TO FIELD VERIFY THE PROPOSED LOCATIONS FOR WALKLIGHTS. MAINTENANCE AND OPERATION OF WALKLIGHTS SHALL BE GRANTED TO THE CITY FOLLOWING INSTALLATION AND OPERATION, TO THE CITY'S FULL SATISFACTION.
2. ALL LIGHT POLES SHALL BE DESIGNED TO WITHSTAND 120 M.P.H. WINDLOADS.



**STANDARD CONSTRUCTION DETAIL  
STREET AND WALKWAY LIGHTS  
"GARDCO LIGHTING"**

FILE NAME:

EW\_M16.DWG

DETAIL REF:

**M-16**

# LUMEC LIGHTING

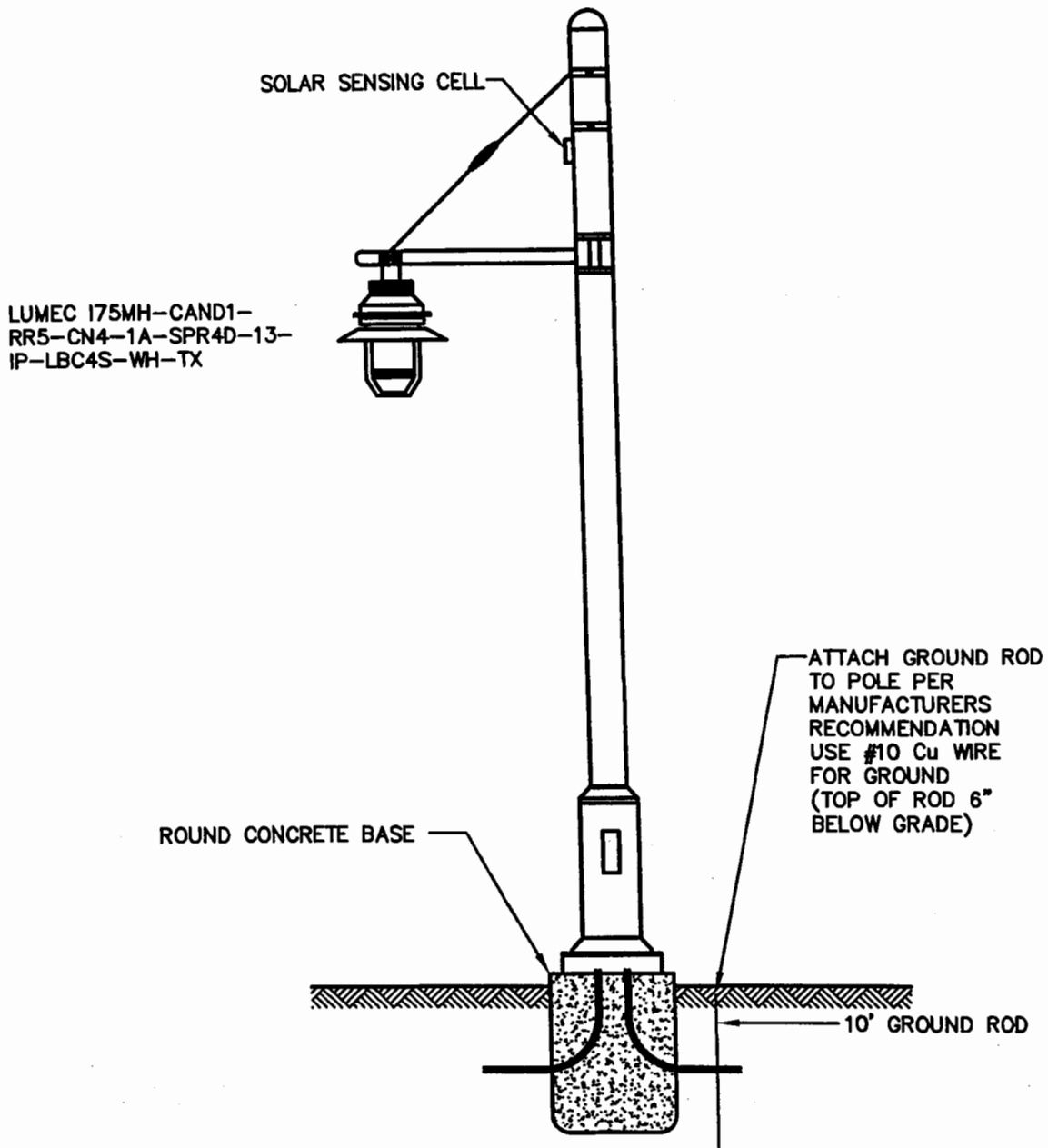

## NOTE:

1. ALL WALKLIGHTS SHALL BE FITTED WITH SOLAR CELLS AND LOCATED ON 100' CENTERS. THE PLANNING DIVISION SHALL BE CONTACTED AT (386) 424-2412 TO FIELD VERIFY THE PROPOSED LOCATIONS FOR WALKLIGHTS. MAINTENANCE AND OPERATION OF WALKLIGHTS SHALL BE GRANTED TO THE CITY FOLLOWING INSTALLATION AND OPERATION, TO THE CITY'S FULL SATISFACTION.
2. ALL LIGHT POLES SHALL BE DESIGNED TO WITHSTAND 120 M.P.H. WINDLOADS.



## STANDARD CONSTRUCTION DETAIL STREET AND WALKWAY LIGHTS "LUMEC LIGHTING"

FILE NAME:

EW\_M17.DWG

DETAIL REF:

M-17

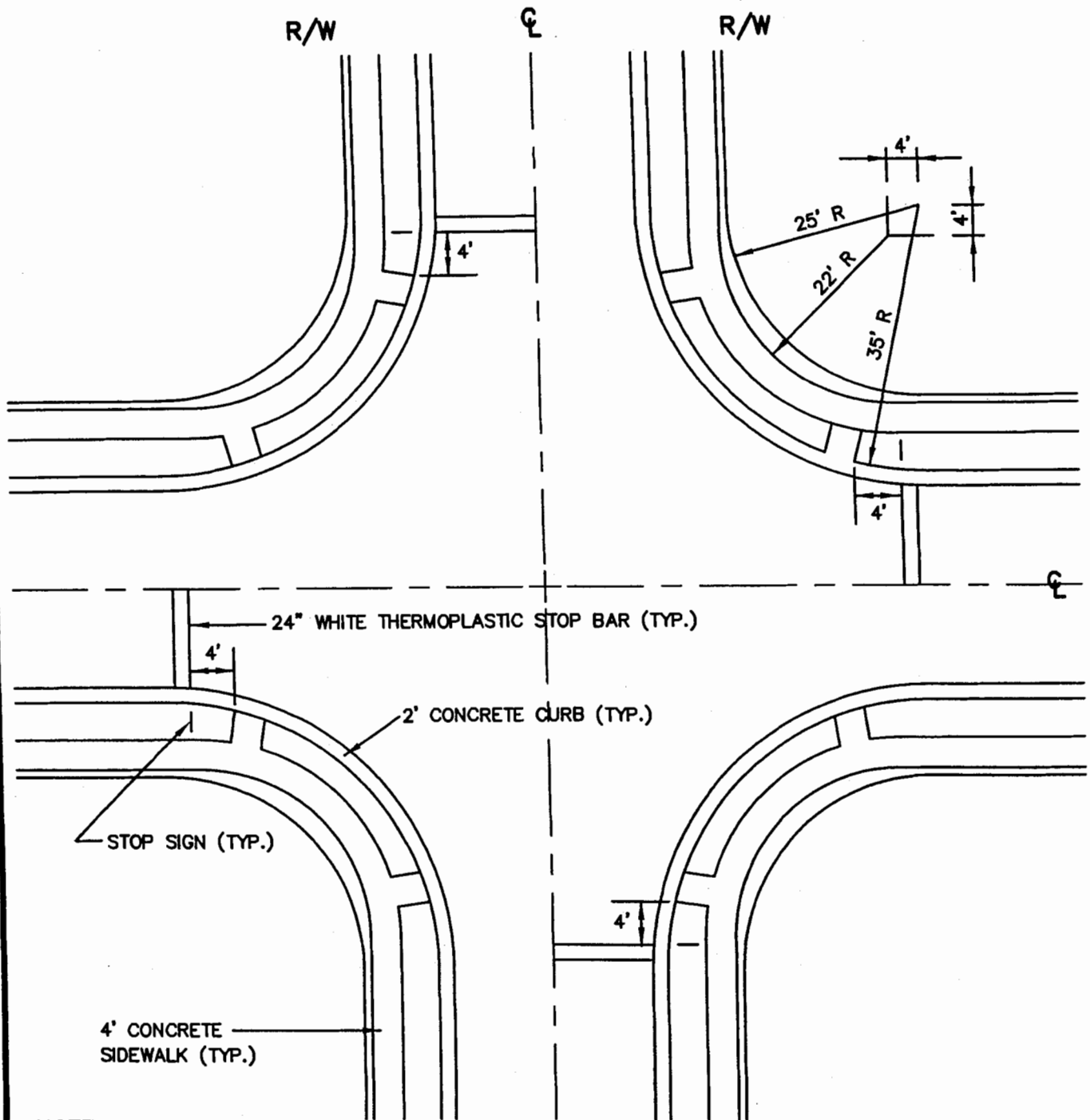

**NOTE:**

1. REFER TO DETAIL SHEET M-2 FOR SIDEWALK CONSTRUCTION SPECIFICATIONS.
2. REFER TO DETAIL SHEET M-3 FOR SIDEWALK & BIKEPATH RAMP SPECIFICATIONS.



**STANDARD CONSTRUCTION DETAIL  
SIDEWALK CONSTRUCTION AT INTERSECTIONS**

FILE NAME:

EW\_M18.DWG

DETAIL REF:

**M-18**

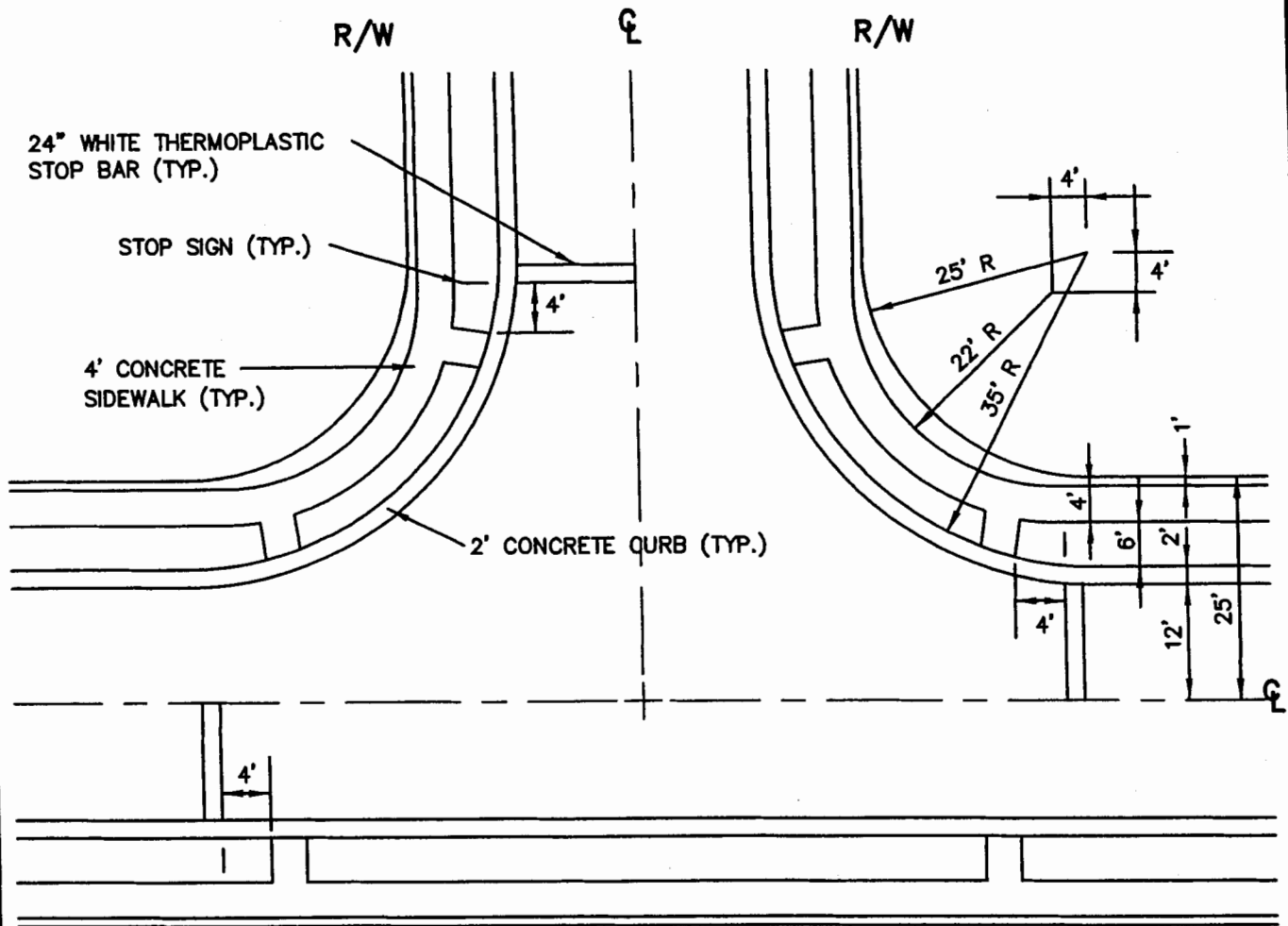

**NOTE:**

1. REFER TO DETAIL SHEET M-2 FOR SIDEWALK CONSTRUCTION SPECIFICATIONS.
2. REFER TO DETAIL SHEET M-3 FOR SIDEWALK & BIKEPATH RAMP SPECIFICATIONS.



**STANDARD CONSTRUCTION DETAIL  
SIDEWALK CONSTRUCTION AT INTERSECTIONS**

**FILE NAME:**

EW\_M19.DWG

**DETAIL REF:**

**M-19**